

DVV Ex

Installation and Operating Instructions for



■ English original version



Previous issue: IMO_DVV4g_Ex_de_en_23_02_2015_Am_13_02_2018

Changes:

- Update of intended use 2.3
- Update of description (5)
- Technical data (5.1) – warnings about weight
- Electrical connection (7) – service switch added
- APP1 (gap + overlap)
- APP3 (name plate and type key)
- Update of declaration

The data stated in these operating instructions are merely for the purpose of describing the product. Information about a certain property or suitability for a certain purpose of use cannot be derived from our information. The information does not release the user from his own assessments and examinations.

Please consider the fact that our products are subject to a natural wear and ageing process.

All rights are with Systemair d.o.o., also for the event of applications for protective rights.

Any powers of use, such as copying and forwarding rights, are with us.

An exemplary configuration has been shown on the title page. The product supplied can therefore deviate from the illustration. The original operating instructions have been written in the English language.

Table of contents

1. General information	4	7.2	Connection of thermal protection	10
1.1 List of information	4	8. Commissioning	10	
1.2 Specific safety symbols	4	8.1 Preconditions	10	
1.3 Notes on the documentation.....	5	8.2 Commissioning.....	11	
2. Important safety information	5	8.2.1 Safety elements.....	11	
2.1 Safety notes	5	9. Operation	11	
2.2 Personnel	5	9.1 Safety notes	11	
2.2.1 Mounting personnel	5	9.2 Operating conditions.....	11	
2.2.2 Work on the electrical equipment.....	5	9.3 Operation/use	12	
2.2.3 Personnel for operation, use, maintenance and cleaning.....	5	10. Maintenance/Troubleshooting	12	
2.3 Intended use	5	10.1 Malfunctions and troubleshooting	13	
2.4 Improper use	6	10.2 Cleaning.....	13	
3. Warranty	6	10.3 Maintenance, service	13	
4. Delivery, transport, storage	7	10.4 Spare parts	14	
4.1 Delivery	7	11. Uninstalling/Dismounting	15	
4.2 Transport	7	12. Disposal	15	
4.3 Storage.....	7	12.1 Disposal of the fan	15	
5. Description	7	12.2 Disposal of packaging.....	15	
5.1 Technical data.....	8			
5.2 Dimensions	8	Appendix 1: Gap nozzle - impeller, distances, crosssection		
6. Intallation	8	Appendix 2: Wiring diagram		
6.1 Safety information	8	Appendix 3: Name plate and type key		
6.2 Preconditions for installation.....	8	EC-Declaration of Conformity		
6.3 Installation	9			
7. Electrical connection	9			
7.1 Protect the motor	10			

1. General information

1.1 List of information



DANGER

Direct danger

Failure to comply with this warning leads directly to death or to serious bodily harm.



WARNING

Possible danger

Failure to comply with this warning potentially leads to death or to serious bodily harm.



CAUTION

Hazard with a low risk

Failure to comply with this warning potentially leads to moderate injuries.

ATTENTION

Hazard with risk of property damage

Failure to comply with this warning leads to property damage.



NOTE

Useful information and notes

1.2 Specific safety symbols



WARNING

Hazard from electrical current!

This warning identifies situations with a danger for life from electrical current. Failure to comply with this warning leads to the risk of death or serious injuries.



DANGER

Explosion-protection!

This warning identifies contents and instructions in these operating instructions which apply when using the appliance in explosion-capable areas. Failure to comply with these contents and instructions leads to a loss of explosion protection and can lead to serious injuries and death.



WARNING

Hazard from hot surface!

This warning identifies situations with a danger from overheating. Failure to comply with this warning potentially leads to property damage.

1.3 Notes on the documentation



WARNING

Hazard as a result of improper dealing with the fan

These operating instructions describe safe use of the fan.

- Read the operating instructions carefully!
- Keep the operating instructions with the fan. They must be permanently available at the place of use.

2. Important safety information

2.1 Safety notes

Designers, installers and operators are responsible for the proper mounting and intended use.

- Only use the fan in a proper condition.
- Provide generally prescribed electrical and mechanical protective devices.
- During mounting, commissioning, maintenance and control, secure the place of mounting against unauthorised access.
- Observe rules for safe work.
- Safety components must not be bypassed or put out of function.
- Keep all the warning signs on the fan complete and readable.
- Regularly instruct the personnel about safety-conscious behaviour.



NOTE

We have carried out a risk assessment for the fans. However, it can only apply to the fan itself. After installation of the fan, we recommend to carry out a risk assessment for the whole system. In this way, you have the guarantee that there is no risk potential from the system.

Compliance with EMC Directive 2014/30/EU only relates to these products when they have been connected directly to the customary energy supply mains.

2.2 Personnel

2.2.1 Mounting personnel

- Mounting may only be carried out by trained, qualified personnel.

2.2.2 Work on the electrical equipment

- Work on the electrical equipment of the fan may only be done by a qualified electrician or electrotechnically educated person. This person must know the relevant safety rules to recognise and avoid potentially risks.

2.2.3 Personnel for operation, use, maintenance and cleaning

- Operation, use, maintenance and cleaning may only be carried out by trained and authorized personnel. The operating personnel must have appropriate knowledge about handling with the fan. In the case of a malfunction or an emergency they must react correctly and adequately.

2.3 Intended use

DVV Ex fans are intended for installation in ventilation systems. They can be installed either in duct systems or as a free sucking fan over a nozzle and a sucking side protection grid.

- DVV Ex fans are suitable for extraction of clean air, air with a low dust and grease content, media up to max. density of 1,3 kg/m³ and permissible moisture of max. 95 %.
- The maximum permissible operating data on the name plate apply for an air density $\rho = 1,2 \text{ kg/m}^3$ (sea level) and a maximum air moisture of 80 %.
- Roof fans DVV Ex with electric motor in explosion protection »flameproof enclosure« (Ex d) are only intended to exhaust potentially explosive atmospheres from zones 1 or 2, field of application II, installation in zones 1, 2, or in not explosion hazardous areas, as well as accordingly with the marking of explosion protection (gases of the groups IIA, IIB and H₂, temperature classes T1 – T4), duty type S1 - continuous operation. The fans are classified to category 2G up to Directive 2014/34/EU. They are suitable for installation outside buildings only (on roofs).
- Media temperature and ambient temperature limits depending on the Ex-identification:

Ex-identification of the fan	Media temperature	Ambient temperature	Gas group	Temperature class
II 2G Ex h IIB+H2 T4 Gb	$-20 \leq T \leq +40^\circ\text{C}$	$-20 \leq T_a \leq +40^\circ\text{C}$	IIA, IIB, H ₂	T1, T2, T3, T4
II 2G Ex h IIB+H2 T4 Gb ($-20 \leq T_a \leq +55^\circ\text{C}$)	$-20 \leq T \leq +55^\circ\text{C}$	$-20 \leq T_a \leq +55^\circ\text{C}$	IIA, IIB, H ₂	T1, T2, T3, T4
II 2G Ex h IIB+H2 T4 Gb ($-40 \leq T_a \leq +40^\circ\text{C}$)	$-20 \leq T \leq +40^\circ\text{C}$	$-40 \leq T_a \leq +40^\circ\text{C}$	IIA, IIB, H ₂	T1, T2, T3, T4

2.4 Improper use

Above all, the improper use means using the fan in a way other than that described. The following points are improper and hazardous:

- Use of a fan with improper Ex-identification (category, gas group, temperature class or ambient temperature);
- Not suitable to exhaust dust containing medium or medium with such dust concentration, that could affect with dust deposits on operation and explosion protection (appropriate filtering necessary);
- Extraction of grease containing media;
- In case of suction aggressive atmosphere additional acid protection of exposed parts is necessary;
- Not suitable for indoor use;
- Operation without duct system or protective guard;
- Operation with the air connections closed;
- Operation without effective thermal protection (PTC).

3. Warranty

Warranty for our products shall be determined according to the contractual agreements, our quotations and also, as a supplement, our General terms and Conditions of Business. Warranty claims shall presuppose that the products are correctly connected, operated and used accordingly to data sheets, and also regularly maintained.

4. Delivery, transport, storage

4.1 Delivery

Each device leaves our plant in an electrically and mechanically proper condition. The fans are delivered in wooden crates. We recommend to transport them to the installation site in original packaging.



CAUTION

Danger from cutting edges!

- Wear protective gloves when unpacking.

Check delivery

- Check the fan for obvious defects, which can impair safe operation.
- First of all, pay attention for defects on the connection cable, terminal box and impeller, cracks in the housing, missing rivets, screws or covering caps.

4.2 Transport



WARNING

Hazard of impact if the fan falls down!

- Transport the fan carefully and with appropriate hoisting device!
- Wear a safety helmet and safety goggles!



WARNING

Electrical hazard from damaged connection cable or connections

- Do not use the connection cable, terminal box or impeller for transport.

- Transport and unload the wooden crate carefully.
- Transport the fan either in the original packaging or on the provided transport devices (lifting eyes) with appropriate hoisting devices.
- Only put the ventilator at unpacking on its base plate.
- At manual transport observe allowed human lifting resp. carrying forces (see weight on the name plate).
- Avoid impacts and distortion of the base plate and other parts of housing.

4.3 Storage



CAUTION

Hazard due to loss of function of the motor bearings!

- Avoid storing for too long time (recommendation: max. 1 year).
- Turn the impeller manually every three months, wear safety gloves.
- Before installation, check proper function of the motor bearings

- Store the fan in the original packaging dustproof, dry and protected against weather.
- Avoid effects of extreme heat or cold.

5. Description

Roof radial fans type DVV Ex with electric motor in explosion protection »flameproof enclosure (Ex d)« are intended to exhaust potentially explosive atmospheres according to fan`s Ex-identification.

The octagonal casing is manufactured from seawater resistant aluminium. The base plate with nozzle consists of hot-dip galvanized steel. The inlet nozzle is coated with copper sheet. Impellers with backward-curved blades are welded and galvanized. They are fastened together with hub and secured screw directly on to the motor shaft. Dynamically balanced to BV-3, ISO 14694. The earthing connection of electric motor is connected by a copper rope with the base plate.

Additional sound attenuator HSDV is available on request, factory mounted as DVVI-Ex fan.

Serial equipped with B5 electric motors 3x400V~, 50Hz, IP 55, insulation class F, with built-in PTC.

Electric motor	Connection
Single speed (4 pole, 6 pole, 8 pole)	Y or D
Two speed (4-6, 6-8)	Y/Y
Two speed (4-8) Dahlander	YY/Y

5.1 Technical data

Size	Max. synchron RPM at 50 or 60 Hz	Max. nominal power at 50 Hz*	Impeller diameter	Max. weight** DVV Ex	Max. sound power level inlet	Max. sound power level outlet**
	min-1	kW	mm	kg	dB(A)	dB(A)
560 XS, XM, XL	1500	2,2	520, 570	114	90	90
630 XS	1500	3	650	145	92	94
630 XM	1500	4	650	159	94	96
630 XL	1500	5,5	650	183	97	98
800 XS	1000	3	820	260	84	86
800 XM	1000	4	820	270	87	89
800 XL	1000	5,5	820	274	91	93
1000 XM	1000	7,5	980	379	92	95
1000 XP	1000	11	980	403	93	96
1000 XL	1000	11	980	405	92	94

*Motor data (input power P1, current, RPM) and data of the fan are visible on the name plate and on the test protocol. Motor data may slightly deviate from catalogue depending on different supplier.

**Single speed motors, without HSDV. The weight may deviate from catalogue depending on different supplier.

5.2 Dimensions

Are on-line available (www.systemair.com).

6. Installation

6.1 Safety information



WARNING

Hazard from falling parts!

- Check the base before installation for load capacity/strength.
- When selecting the hoisting device and fitting material observe the weight, tendency to vibrations and shear forces (weight information on the name plate).

6.2 Preconditions for installation

- Fans DVV-Ex must be installed on roofs.
- The fans must be mounted on a flat, horizontal roof base (<10 mm/m) with height of min. 250 mm over the roof top (motorshaft vertical). The base shall be accordingly designed (load capacity, stiffness, insulation, explosion protection, grounding), if not proved Systemair accessories used.
- Installation site must be protected from dust, moisture and weather influences.

6.3 Installation

- Ensure secure access to the fan for maintenance and service.
- Fit the contact surface between base plate and roof base with sealing tape. Systemair roof bases (for DVV Ex marked with „Ex“) are delivered with appropriate sealing tape.



DANGER

Explosion-protection!

Before and after mounting check manually if the impeller rotates smoothly. Install the fan only, if the minimum air gap between rotor and nozzle matches the value from Appendix 1.

- The fans shall be fixed to the base with 4 screws in the corners.
- Avoid distortions of the casing at installation.
- Ensure unobstructed and uniform intake into the fan as well as free outlet.
- Install connecting ducts and accessories. The suction side of the fan is provided with a connection for flange-type mounting of the air duct according to Eurovent.
- Provide for contact/suction protection and safety distances according to EN ISO 13857.



NOTE

In some cases it is better to mount accessories before placing the fan on the roof base.



NOTE

It is recommended to install a conductive flexible connection between the fan and duct to avoid eventual tensions or distortions of the base plate. The flexible connection has to comply guidelines for the prevention of ignition hazards due to electrostatic charges (also as certified Systemair accessories available).



NOTE

Mounting examples with accessories are on-line available (www.systemair.com).

7. Electrical connection

The wiring diagram is placed on the cover of connection box or service switch (inside).

- In case of using connection box on the fan install appropriate service switch outside hazardous zone to control the fan at maintenance/service/cleaning.
- Service switch in explosion protection II 2G Ex db eb IIC T6 Gb is accessory, factory mounted on the fan instead of connection box, if ordered.



NOTE

- Motors have serial built-in PTC. More than two PTC chains may not be switched in series, as this can lead to undefined cut-outs.
- Maximum check voltage of PTC is 2,5 V (to reduce influence on the result of measurement).
- The wiring diagrams see Appendix 2.

WARNING
Hazard from electrical voltage!

- Electrical connection only by a trained electrician resp. trained and instructed qualified personnel!
- Electrical connection in accordance with the valid regulations.
- Prevent the ingress of water into the connection box.
- Observe 5 safety rules for the electrical expert!
 - disconnect from the power supply (all-pole),
 - prevent switching on again,
 - test absence of voltage,
 - earthing and short-circuiting,
 - protect adjacent live parts by covers and barriers and fit a suitable warning notice.

- Connect the cable according to wiring diagram.
- Use only Ex-approved cable gland fittings.
- Tighten the nuts of cable glands well to achieve IP68 protection.
- Check, if the cover of connection box or service switch is uniformly fastened.
- Place the supply cable.
- Ground all conductive parts and accessories.

DANGER
Explosion protection!

Motor protection devices and frequency converters must be installed outside explosion hazardous areas!

7.1 Protect the motor

- Avoid two-phase running:
at 3-phase motors, use an all-pole C-safety cut-out (current consumption, see name plate).

7.2 Connection of thermal protection

CAUTION
Property damage as a result of motor overheating

- The motor can overheat and be destroyed if the PTC not been connected.
- PTC always connect to a motor protective device!

8. Commissioning

8.1 Preconditions

- Mounting and electrical connection have been correctly performed.
- Installation residuals and foreign objects have been removed from the fan and ducts.
- Inlet and outlet are free.
- The safety devices have been fitted (protection against contact).
- The protective conductor and external earth conductor have been connected.
- The thermal protection is properly connected to the motor protective device:
- the motor protective device is functional;
- the thermal protection is functional.
- The cable glands are tight.

- Provided mains connection complies with the data on the name plate.
- The current (from the name plate) does not exceed the mains data.
- All conductive added and accessory parts have been earthed.

8.2 Commissioning



WARNING

Hazard from electrical voltage!

- Commissioning by trained and instructed qualified personnel only!

- Switch the ventilator on as planned.



WARNING

Hazard from bursting parts!

- When checking the direction of rotation, wear safety goggles.

Check:

- the direction of rotation (all speed!). Switch the fan for a short period on and then off to check the direction of rotation of impeller. It is visible through a hole on the casing. The rotation must comply with the arrow on the casing. If wrong, swap two phases.
- smoothly running (eventual vibrations and noise);
- current with appropriate instrument;
- tightness of all joints.
- Fill in the attached test protocol and submit it in case of warranty claim.

8.2.1 Safety elements

- Check, if safety elements e.g. protective guards are fastened.

9. Operation

9.1 Safety notes



WARNING

Hazard from electrical voltage!

The device may only be operated by persons:

- instructed in function and risks,
- who have understood handling and can accordingly react.
- Ensure access only to persons, who can safe handle the device.



DANGER

Explosion protection!

Intervention in the fan or in a connected system is allowed only if no potentially explosive atmosphere present and if there is no danger to appear it!

9.2 Operating conditions

- During operation, touching the impeller must not be possible.
- Safety components must not be bypassed or put out of function.
- The fan may operate only within the limits declared on the nameplate, operation over 50 Hz is not allowed (exception: the fan can be approved for 60 Hz operation, if synchronous speed at 60 Hz does not exceed the data from the table in section 5.1; in that case the fan will be accordingly designed and marked on the nameplate).

- Prevent sucking of foreign particles , this can destroy the fan.
- Switching frequency:
 - the fan is intended for S1 continuous operation!
 - the control equipment must not allow any extreme switching!

ATTENTION

Hazard with risk of additional costs

- In case of speed control via frequency converter - min. 20 Hz ÷ max. 50 Hz (rsp. 60 Hz, if declared for 60 Hz), it is recommended use of combination of frequency converter and appropriate all-pole sine filter (or dU/dt filter). It is particularly important, if the supply cable is long, but also to reduce the motor noise. Filters may only be abandoned, if proven, that the voltage peaks on the connection terminals of the fan are inside limits up to IEC 60034-17. The peaks shall be lower than the limits U_{LL} 1350 V and the rise time longer than 0,8 μ s. Shorter rise time requires lower peaks. Not observing this, the motor life time could be shorter.
- At all single speed motors there are 4 wires (+PTC) led to connection box. **Starting “star – delta” is not possible!**

9.3 Operation/use

- Only use the fan in accordance with this operating instruction and the operating instructions of motor.
- Control the fan during operation for correct function.
- Switch the fan off as planned.



WARNING

**Hazard from electrical voltage and flying parts!
Errors occurring can lead to personal and/or property damage!**

Switch the fan off as planned:

- In cases of a non-typical noise from bearings, vibrations, pressure pulsation.
- In case of overcurrent, overvoltage or temperature (nameplate).

10. Maintenance/trouble setting



WARNING

Hazard from electrical voltage!

- Trouble setting and service only by a trained electrician or trained and instructed qualified personnel!
- Observe rules for safe work while troubleshooting!
- Observe 5 safety rules for the electrical expert!
 - disconnect from the power supply (all-pole),
 - prevent switching on again,
 - test absence of voltage,
 - earthing and short-circuiting,
 - protect adjacent live parts by covers and barriers and fit a suitable warning notice.



DANGER

Explosion protection!

Intervention in the fan or in a connected system is allowed only if no potentially explosive atmosphere present and if there is no danger to appear it!



⚠️ WARNING

Hazard from electrical voltage!

Observe at maintenance and service:

- Impeller must stand still.
- Electrical circuit must be interrupted and secured against restarting.
- Observe the rules for safe work.



⚠️ CAUTION

Danger from hot surfaces!

- During maintenance and cleaning wear protective gloves!

10.1 Malfunctions and service

The ventilator does not run	Check connection to the mains and thermal protection. If ok. check electric motor. If two speed motor (4-6, 6-8, 4-8, 6-12) is installed, check all speed. If necessary get the electric motor repaired.
Air volume is too low	Check the direction of rotation. If wrong, swap the supply connection of any 2 phases. Check if current is similar all phases. If ok. check operating point and system design (too high pressure loss, obstacles in duct).
Thermal protection switches off	Compare connection with wiring diagram. Compare the data of electric motor with setting of thermal protection. If ok. check power supply and electric motor (short-circuit, damage to the bearings, impeller blocked or grinding). Get the electric motor or if necessary the complete fan repaired.
	Overcurrent. Check the direction of rotation. If wrong, swap any 2 phases. Check if current is similar all phases.
Noise	Damage to the bearings, impeller blocked or grinding. Get the electric motor or if necessary the complete fan repaired.
	Loose fit on the base plate or motor support. Tighten the bolts, look for the cause of vibrations.
Vibrations	Check operating point and system design. If the actual pressure drop of the system is higher than supposed, the fan could operate in an unstable area of the fan curve. Consult customer service of the manufacturer.
	Damage or dust layer on impeller. Clean the impeller, if necessary balance it or replace it.

If the reason for malfunction cannot be clearly determined, consult the customer service of manufacturer.

10.2 Cleaning

Regular cleaning prevents unbalance.

- Keep casing clean and clean it if necessary with a brush (do not use a steel brush or high-pressure cleaner). Do not use any detergents for interior cleaning. Regular cleaning is particularly important, if there are trees in the neighbourhood. The gap between casing and base plate must be kept free for water drain and may not be covered by needles or leaves.

10.3 Maintenance, service



⚠️ DANGER

Loss of explosion protection!

Basically the fan may be repaired at the manufacturer only! Failure to this would expire the ATEX approval (basically, always consult the manufacturer). Exceptions are non-relevant components. They can be performed on site by qualified personnel.

The fan is by built-in for-life lubricated ball bearings as far as possible low-maintenance product. After their life time (app. 30.000 to 40.000 h), a replacement of the bearings is necessary. Observe attached instructions of motor manufacturer.

- Pay attention to a non-typical noise from bearings.
- For damages (e.g. damage to winding) please contact our Service Department. Repairs may be accomplished only in the company of manufacturer and by the manufacturer. You find the address on the back of these operating instructions.

Maintenance and check points of fans similarly to VDMA 24186-1 (type, scope and maintenance intervals to be specified in dependence of use and operating conditions).

VDMA 24186-1	Description	Maintenance interval		
		Monthly	Every 3 months	Once a year
	Fan and electric motor			
1.1.11	Check the drainage for function			x
6.1.1	Check to dirt, damage, corrosion and fastening		x	
6.1.2	Functional cleaning			x
10.1.6	Check the terminals for tightness			x
10.1.9	Test the fan for function und operational readiness (test run app. 15 min.)		x	
6.1.4	Check the bearings for noise			x
10.1.3	Check impeller for direction of rotation (all speed)			x
6.1.3	Check impeller if damaged or unbalanced (if necessary provide vibration measurement)			x
10.1	Functional test of automatically bridging of all thermal and overcurrent protective devices		x	
10.1.7	Measure the current			x
10.1.12	Test function of protective device		x	
	Triggering device			
	Check it for function	x		
	Test of functions			
	Test all functions of system from control panel as well as signal lights	x		
	Accessories (air ducts, air louvers, flaps, sound attenuators)			
5.5.1	Check accessible ducts inclusive fire protective insulation and fastening for outside damages and corrosion (visually)			x
5.5.4	Check accessible flexible connections for tightness (visually)			x
5.2.1 5.2.3	Flaps and sound attenuators check for dirt, damage and corrosion Check mechanical functionality of the flaps			x
5.1.1	Check air louvers for dirt and damage (visually)			x

10.4 Spare parts

In case of order of spare parts please specify the serial number of the fan. You can find it on the name plate or in the test protocol.

Spare parts: electric motor (at DVV Ex there is a restriction to use only from the test lab allowed motors), impeller, service switch, casing, connection box.

11. Uninstalling/dismounting



WARNING

Hazard from electrical voltage!

- Switching off and uninstalling only by a trained electrician or trained and instructed qualified personnel!
- Observe 5 safety rules for the electrical expert!
 - disconnect from the power supply (all-pole),
 - prevent switching on again,
 - test absence of voltage,
 - earthing and short-circuiting,
 - protect adjacent live parts by covers and barriers and fit a suitable warning notice.



DANGER

Explosion protection!

Intervention in the fan or in a connected system is allowed only if no potentially explosive atmosphere present and if there is no danger to appear it!



CAUTION

Danger from cutting edges and impact!

- Wear protective gloves when dismantling!
- Dismount carefully.



WARNING

Hazard from falling parts!

- When selecting the hoisting device observe the weight (weight information on the name plate).

- Carefully disconnect all wires.
- Remove the fan from duct and roof base. Carefully remove the fastening material.
- Lift the fan with an appropriate hoisting device on the provided lifting eyes. Place the fan on appropriate pallet.

12. Disposal

12.1 Disposal of the fan

Should the fan be disposed, proceed as follows:

- Disassemble the fan into its components.
- Separate the parts according to reusable material and material groups to be disposed (metal, plastics, electrical parts, etc.).
- Provide for the recycling of material. Consider the national regulation.

12.2 Disposal of the packaging

- Provide for the recycling of material. Consider the national regulation.

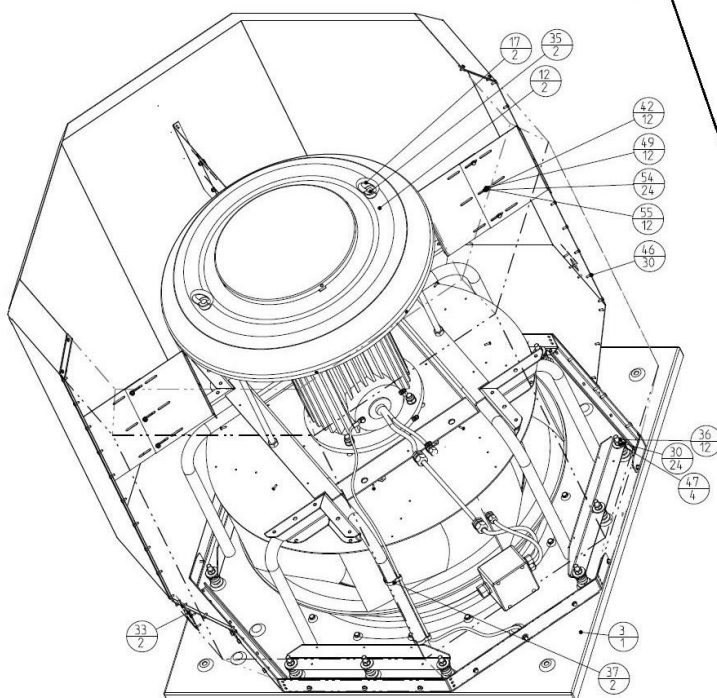
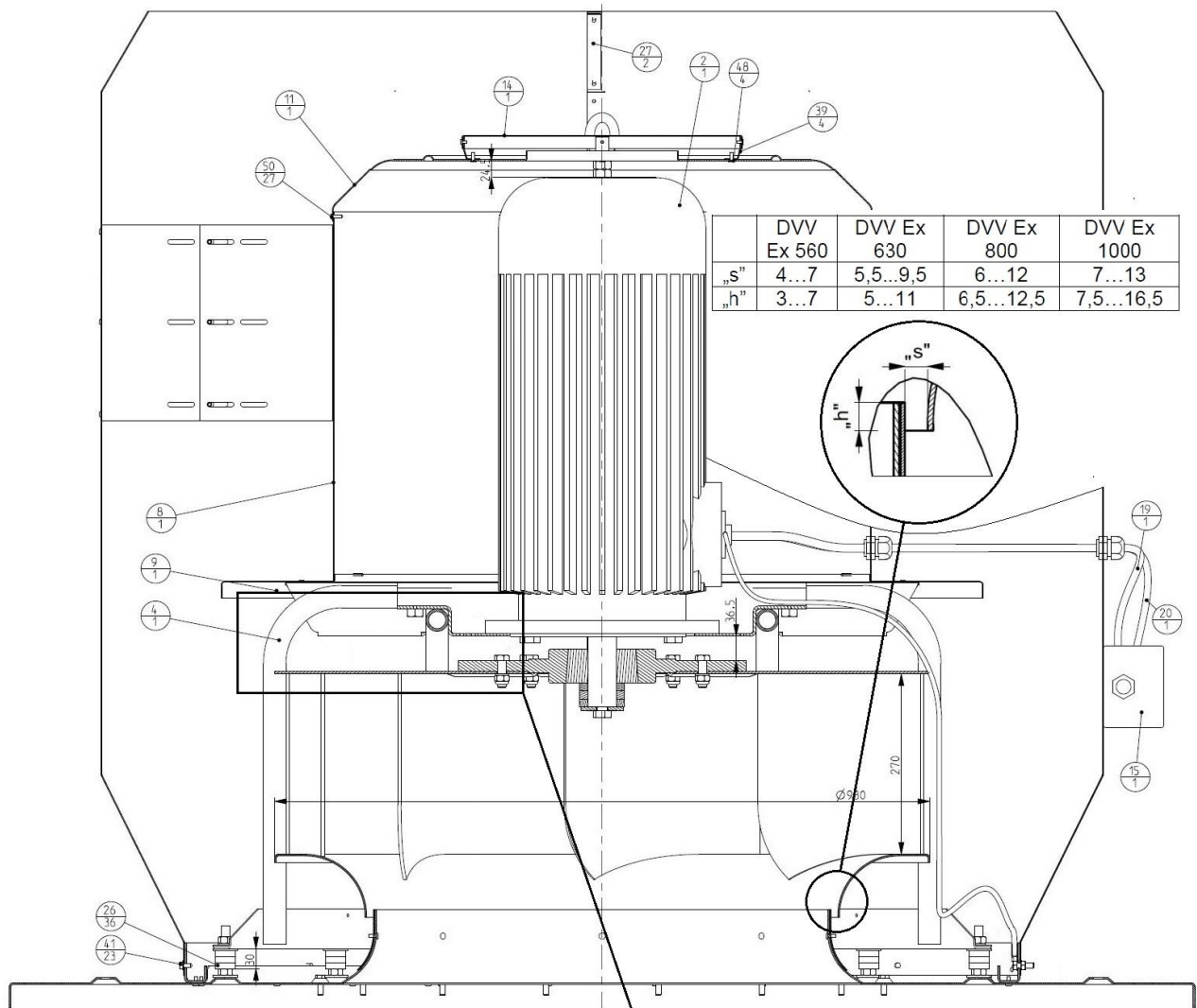

DVV Ex	560	630	800 motor 100-132	800 motor 160	1000 XM, XP	1000 XL
„g” min.	20	20	11	8	40	17

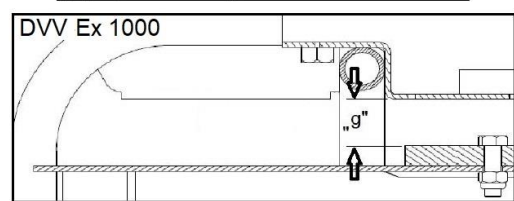
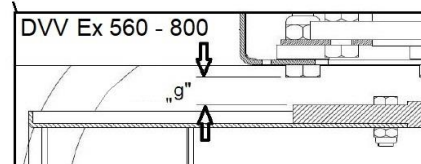

Gap nozzle - impeller („s”), overlap impeller - nozzle („h”), distance impeller - fixed parts („g”)

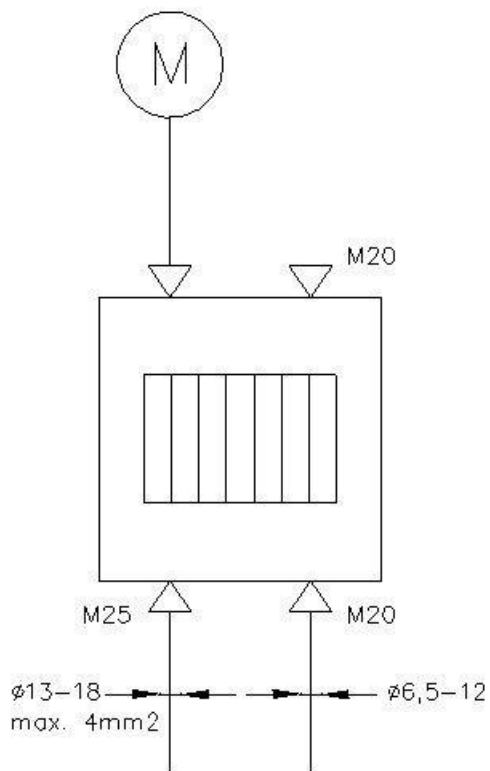
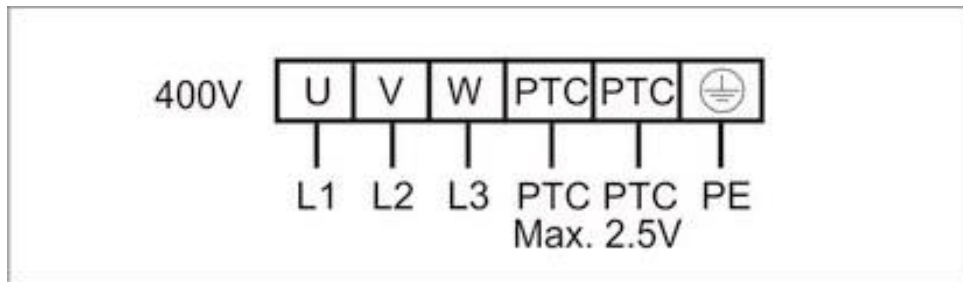

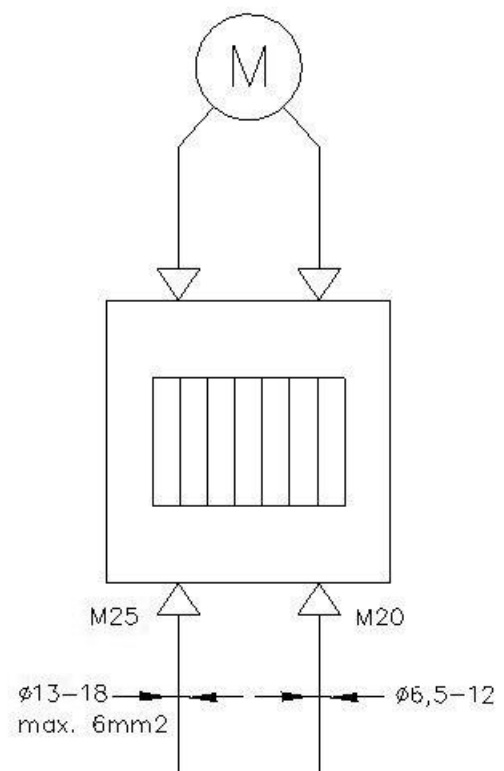

DVV Ex 560-800



DVV Ex 1000

PTC max $2,5\text{ mm}^2$

1. Name plate

				
Systemair d.o.o Špelina ulica 2; SI-2000 Maribor			Manufacturer address	
DVV-EX 560D6-XS			Fan type	
 II 2G Ex h IIB+H2 T4 Gb $-20^{\circ}\text{C} < \text{Ta} < +55^{\circ}\text{C}$			Ex identification Ambient temperature if different to $-20^{\circ}\text{C} < \text{Ta} < +40^{\circ}\text{C}$	
Serial No	XXXXX	Серийный номер	Serial number	
Power supply	Y;3~400V;50Hz	Напряжение пит.	Technical data	
Input power [kW]	0,52	Мощность [кВт]		
Nom. power [kW]	0,75	Ном.мощность [кВт]		
I [A]	1,5	Ток [А]		
RPM [min-1]	915	Число об.[об/мин]		
Max.airflow [m3/h]	5350	Макс. расх.[м3/час]		
mass [kg]	103	Масса [кг]		
IP, Insul. Class	55 F	Ст.защ.,Класс изо.		
Motor	4KTC 90 S-6 IE3	Мотор		Electric motor type
Certificate	EPS 21 ATEX 2 152 X	Сертификаты		Certificate of fan
At installation, commissioning, use and maintenance observe attached instructions! Во время установки, пуска в эксплуатацию, использования и обслуживания необходимо соблюдать данное руководство!			Warnings	
Made in Slovenia	2021	Rotation --->>>---	Rotation direction	
				

2. Type key

Example: DVV Ex 1000D6 XL	
DVV Ex	Roof fan (DVV – without attenuator, DVVI – with attenuator)
1000	Size – approximately outer diameter of impeller in mm (560, 630, 800, 1000)
D	Motor execution (3~ motor)
6	Polarity – 6 pole motor (4, 6, 8, 4-6, 4-8, 6-8)
XL	Impeller type (XS, XM, XP, XL – different blade angle, number of blades and impeller height)

The Manufacturer:

Systemair d.o.o.
 Špelina 2
 SI-2000 Maribor
 Tel.: +386 2 4601 840

certified herewith that the following products: **Roof fans, type DVV/DVVI Ex***

ensure all relevant regulations of following directives:

Directive 2006/42/EC	MD
Directive 2014/30/EU	EMC
Directive 2014/34/EU	ATEX
Directive 2014/35/EU	LVD
Directive 2011/65/EU	RoHS
Regulation 2019/1781/EU	Ecodesign

The following standards are used:

EN 1127-1:2019	Explosive atmospheres - Explosion prevention and protection - Part 1: Basic concepts and methodology
EN ISO 12100:2010	Safety of machinery - General principles for design - Risk assessment and risk reduction
EN ISO 13857:2019	Safety of machinery - Safety distances to prevent hazard zones being reached by upper and lower limbs
ISO 14694:2003	Industrial fans – Specifications for balance quality and vibration levels
EN 14986:2017	Design of fans working in potentially explosive atmospheres
EN IEC 60079-0:2018	Explosive atmospheres - Part 0: Equipment - General requirements
TP CLC/TR 60079-32-1:2019	Explosive atmospheres – Part 32-1: Electrostatic hazards, guidance
EN 60204-1:2018	Safety of machinery - Electrical equipment of machines - Part 1: General requirements
EN 61439-1:2011	Low-voltage switchgear and controlgear assemblies - Part 1: General rules
EN ISO 80079-36:2016	Explosive atmospheres - Part 36: Non-electrical equipment for use in explosive atmospheres - Basic methods and requirements
EN ISO 80079-37:2016	Explosive atmospheres - Part 37: Non-electrical equipment for use in explosive atmospheres - Non-electrical type of protection constructional safety 'c', control of ignition sources 'b', liquid immersion 'k'

*Roof fans DVV/DVVI Ex with electric motor in explosion protection »flameproof enclosure« (Ex d) are only intended to exhaust potentially explosive atmospheres from zones 1 or 2, field of application II, installation in zones 1, 2, or in not explosion hazardous areas, as well as accordingly with the marking of explosion protection (gases of the groups IIA, IIB+ H2, temperature classes T1 – T4 and marking of ambient temperature. The fans are classified to category 2G up to Directive 2014/34. They are suitable for installation outside buildings only (on roofs).

Note: The compliance with EC Machinery Directive and EN ISO 13857 refers to the mounted protective guards on the inlet of the fan. For the fully accordance with mentioned requirements (protective guards or safety assurance in other way) the performer is responsible.

Maribor,
 16.08.2021

 Date



Anton Zupančič, Director