



# Lindab **RCW**

Swirl diffuser



# Swirl diffuser

# RCW



## Description

RCW is a rotation diffuser particularly suitable for rooms with a high ceiling.

The diffuser is equipped with adjustable blades, so the supply air pattern can be changed from vertical to horizontal.

The blade settings can be adjusted manually, or the function can be automated using various types of motor. RCW with manual blade adjustment is supplied as standard with a blade setting of 30°.

The motorized models are supplied as standard with a blade setting from 30° to 75°. In the motorized versions, RCW can be supplied with an electric on/off motor, a modulating motor or a thermal actuator, where the supply air pattern is changed in step with the supply air temperature.

- Suitable for both cooling and heating
- Horizontal and vertical dispersal pattern
- High induction
- Can be supplied with an electric motor
- Can be supplied with a thermal actuator

## Maintenance

The visible parts of the diffuser can be wiped with a damp cloth. For other maintenance, see installation instructions.

## Order code

Product Type	RCW	a	bbb	A
Manual	0			
Motorized - modulating	1			
Motorized- on/off	2			
Thermal actuator	3			
Size				
Version				

## Dimensions

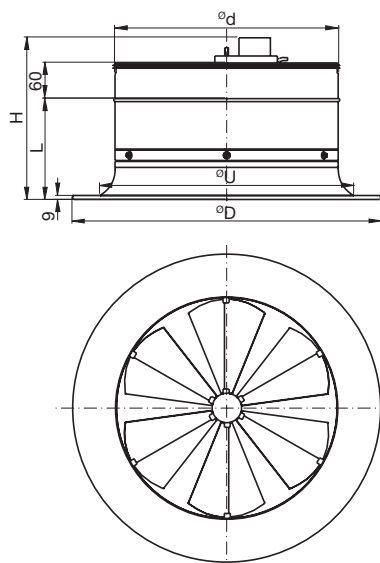

Ød Size	ØD mm	H mm	L mm	ØU mm	Weight * kg
250	360	240	143	285	2.40
315	460	267	168	365	3.10
400	560	292	178	450	4.40
500	670	341	226	570	6.80
630	870	391	273	740	9.90

\* Motorized models weigh approx. 1 kg more than the weight stated in the table above.

## Motortype

RCW-1 Ød	Motor
315-400	NM24A-MF-F
500-630	LH24A-MF60

RCW-2 Ød	Motor
250-400	NM24A-F
500-630	LH24A60

## Materials and finish

Material: Aluminium & steel  
 Standard finish: Powder-coated  
 Standard colour: RAL 9003 or 9010 Gloss 30

Available in other colours. Please contact Lindab's sales department for further information.  
 Other blade settings can be supplied on request.

# Swirl diffuser

# RCW

## Technical data

### RCW with electric modulating motor

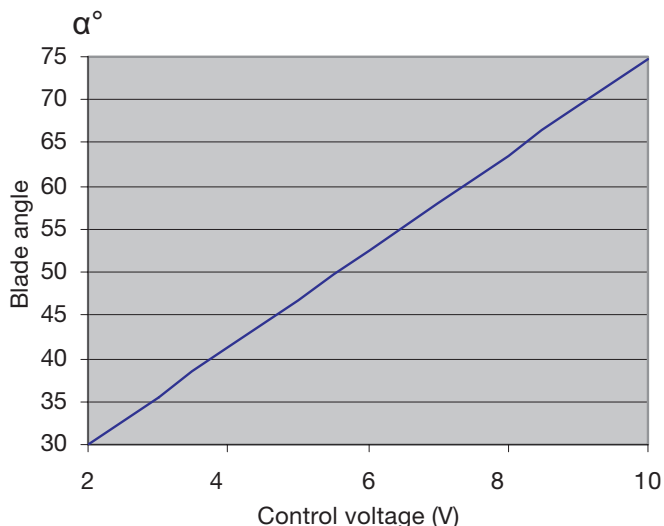

### RCW with thermal actuator

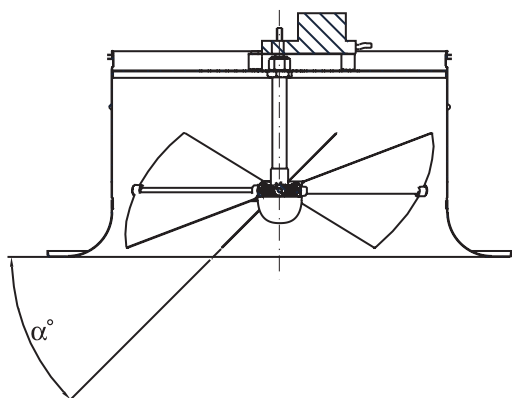
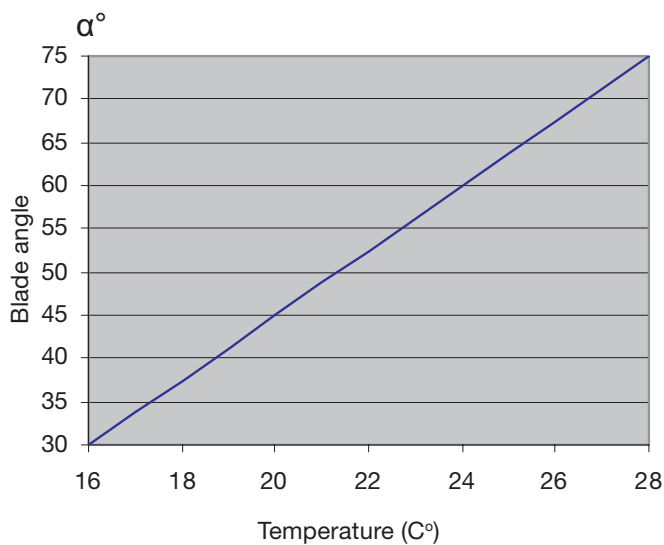

## Capacity

Volume flow  $q_v$  [l/s] and [m<sup>3</sup>/h], total pressure  $\Delta p_t$  [Pa], throw  $l_{0,2}$  [m] and sound power level  $L_{WA}$  [dB(A)] can be seen in the diagrams.

## Throw $l_{0,2}$ / turning point $l_{0,0}$

Throw  $l_{0,2}$  [m] can be seen in the diagrams for isothermal air at a speed of 0.2 m/s. Turning point  $l_{0,0}$  [m] can be seen in the diagrams for heated air, +5 K, +10 K and +15 K respectively.

## Frequency-related sound effect level

The sound effect level in the frequency band is defined as  $L_{WA} + K_{ok}$ .  $K_{ok}$  values are specified in charts beneath the diagrams on the following pages.

## Quick selection

Size	Angle	$q_v$	$q_v$	$P_t$	$l_{0,2}$	$l_{0,0}$
		[l/s]	[m <sup>3</sup> /h]	[Pa]	isotherm [m]	+10K [m]
<b><math>L_{WA} = 40</math></b>						
250	30°	138	498	63	10	
250	75°	138	498	22		5
315	30°	237	854	65	6	
315	75°	237	854	24		6
400	30°	361	1299	60	5	
400	75°	361	1299	22		6
500	30°	453	1630	52	5	
500	75°	453	1630	13		5
630	30°	818	2943	57	6	
630	75°	818	2943	17		7
<b><math>L_{WA} = 50</math></b>						
250	30°	192	692	121	13	
250	75°	192	692	42		7
315	30°	329	1183	124	8	
315	75°	329	1183	46		8
400	30°	513	1846	122	7	
400	75°	513	1846	44		8
500	30°	636	2290	103	6	
500	75°	636	2290	25		6
630	30°	1136	4088	110	8	
630	75°	1136	4088	32		9
<b><math>L_{WA} = 60</math></b>						
250	30°	267	962	234	18	
250	75°	267	962	81		10
315	30°	455	1638	238	10	
315	75°	455	1638	88		11
400	30°	729	2623	247	11	
400	75°	729	2623	89		12
500	30°	893	3216	203	8	
500	75°	893	3216	49		9
630	30°	1577	5679	213	11	
630	75°	1577	5679	62		12

# Swirl diffuser

# RCW

## Technical data

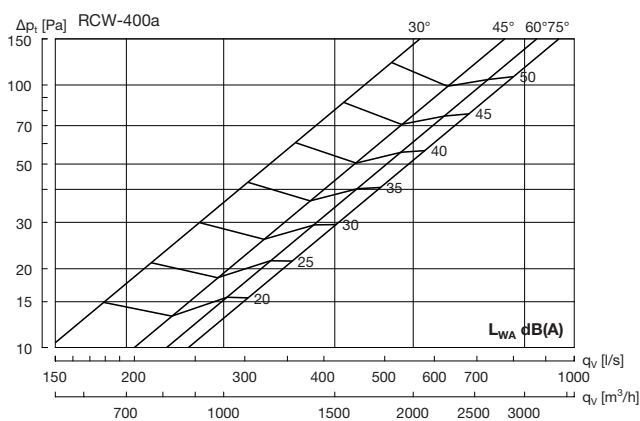
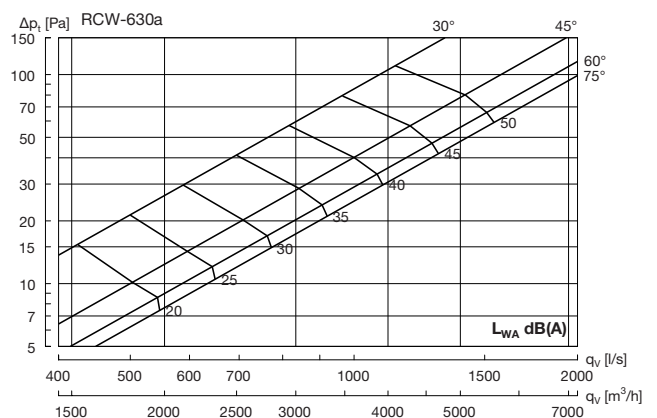
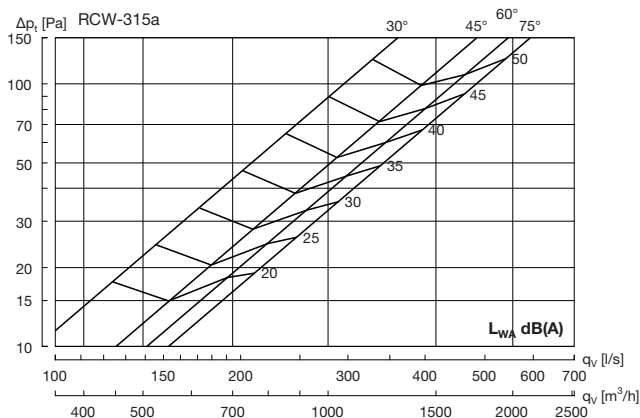
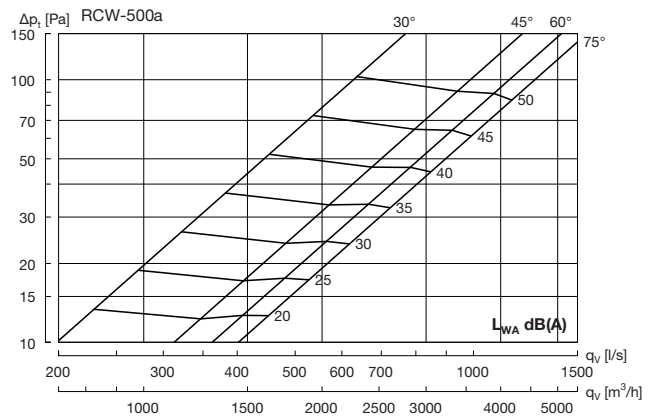
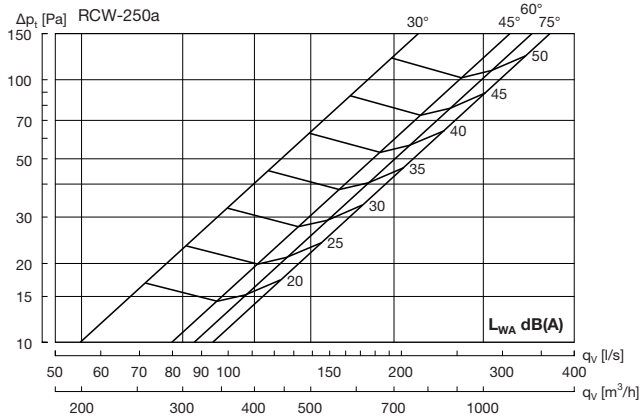

## Throw $I_{0.2}$ horizontal

Horizontal throw  $I_{0.2}$  is specified for free suspension. If the diffuser is installed < 300 mm from the ceiling, the value must be multiplied by 1.4.

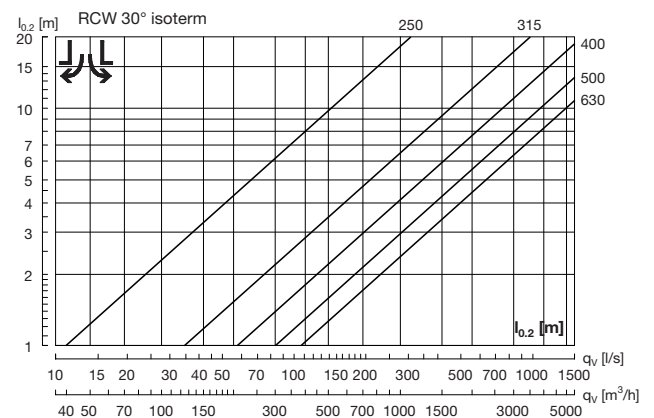

# Swirl diffuser

# RCW

## Technical data

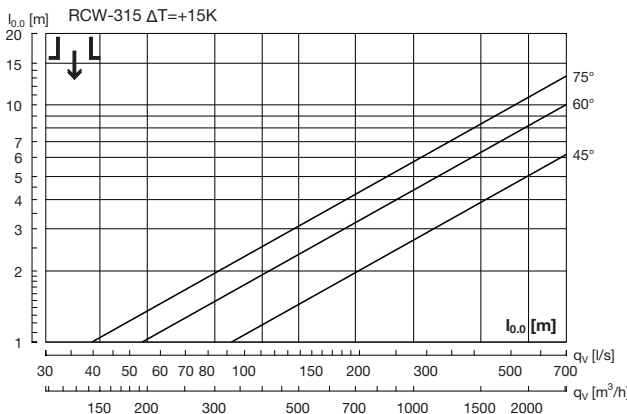
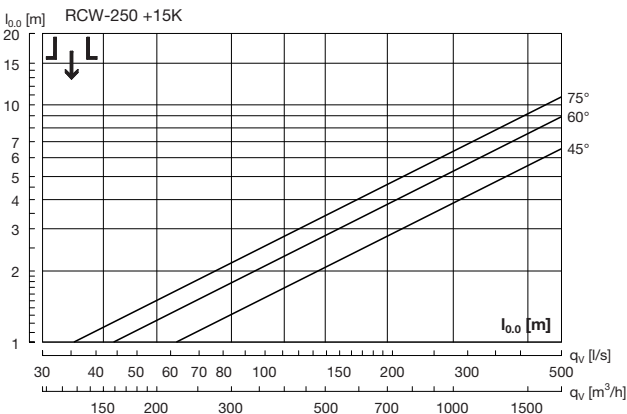
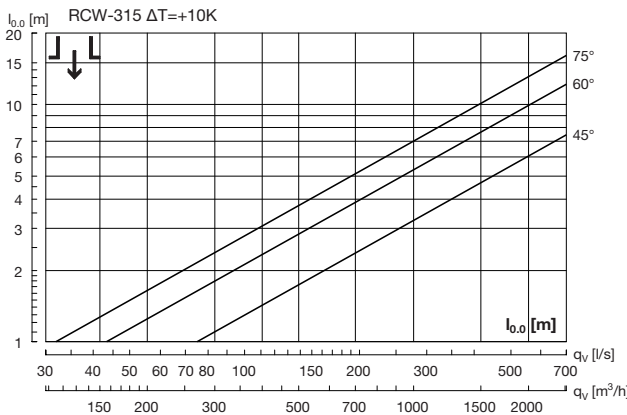
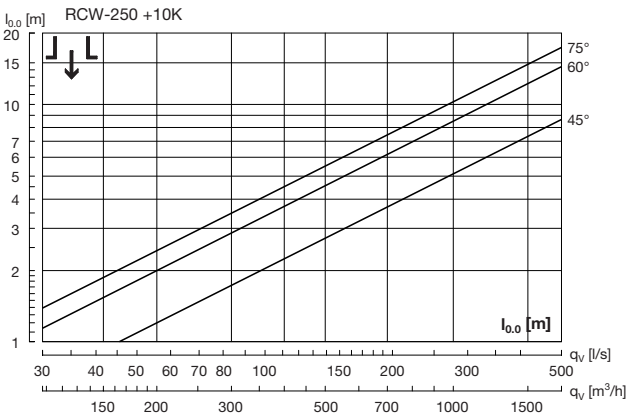
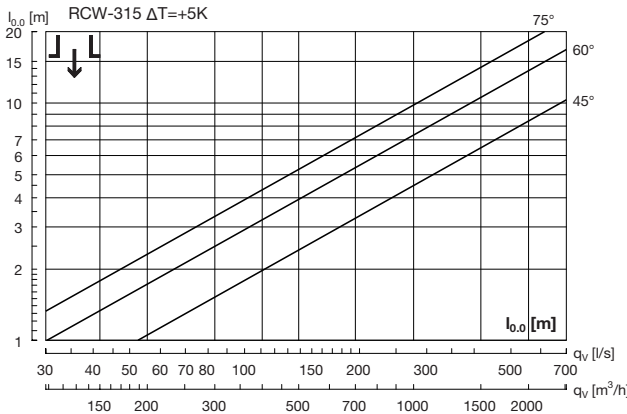
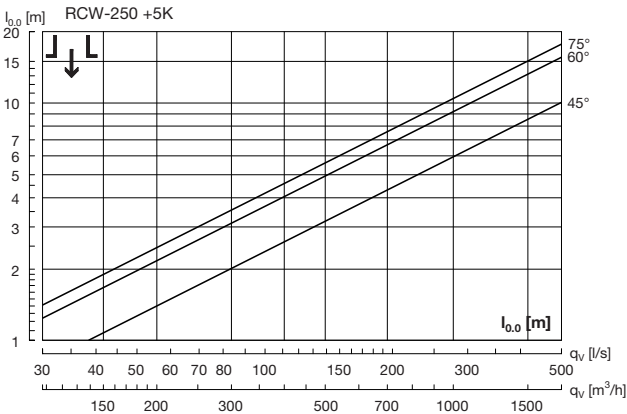
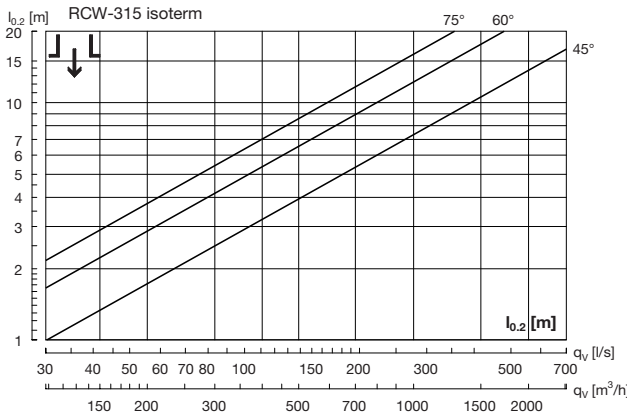
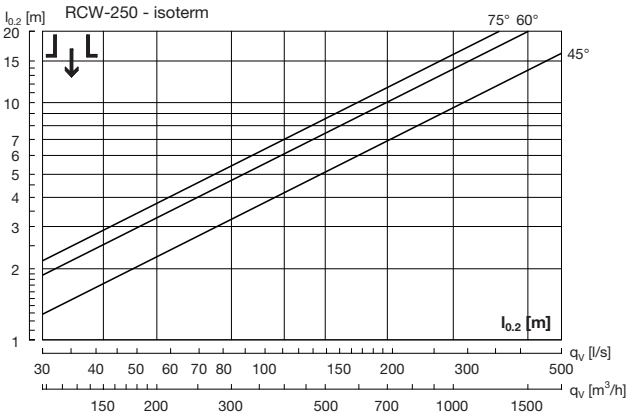

# Swirl diffuser

# RCW

## Technical data

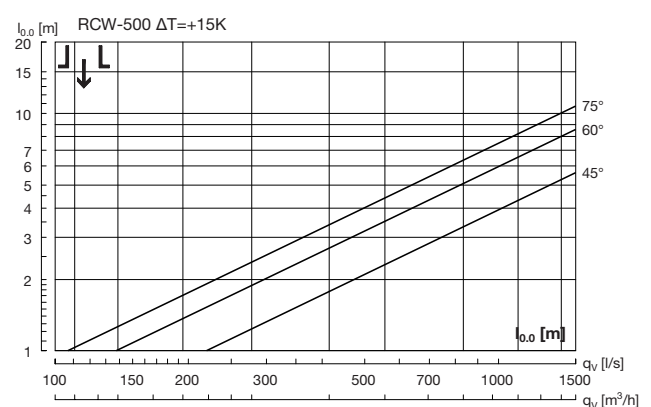
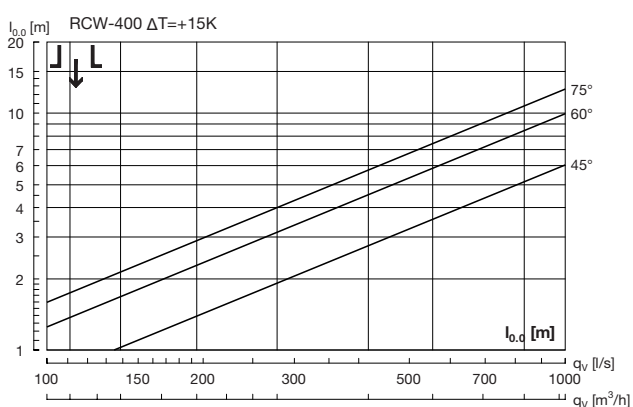
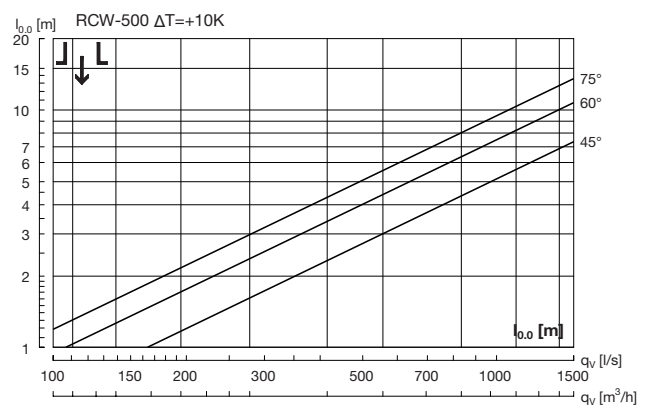
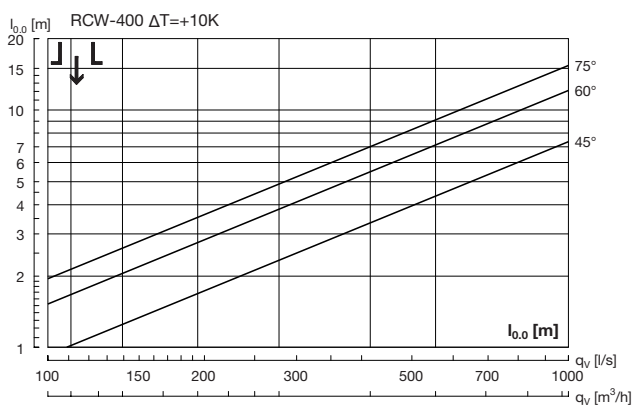
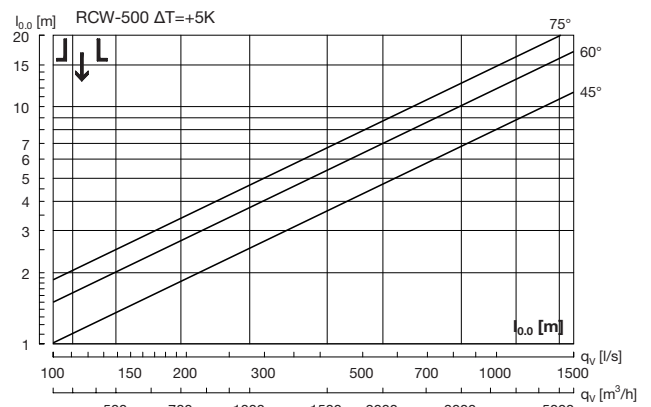
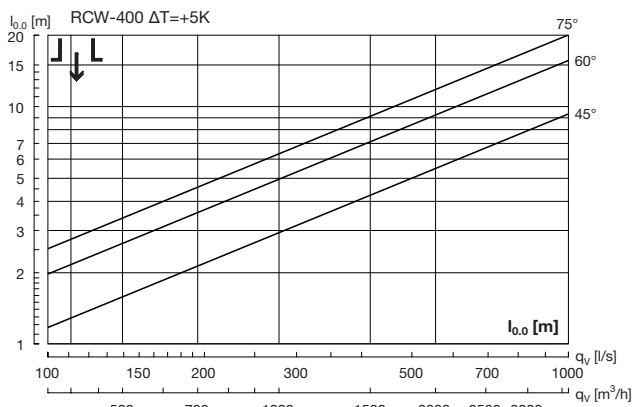
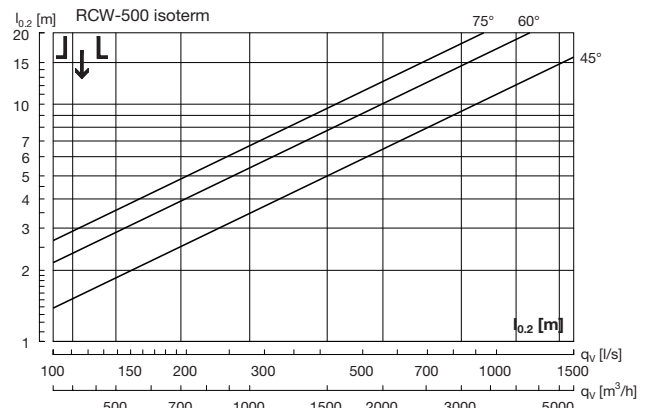
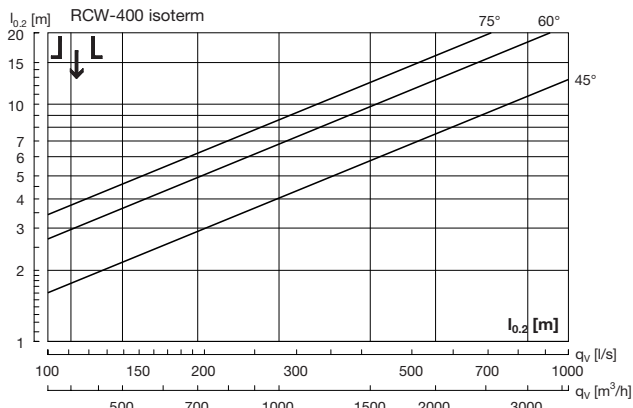

# Swirl diffuser

# RCW

## Technical data

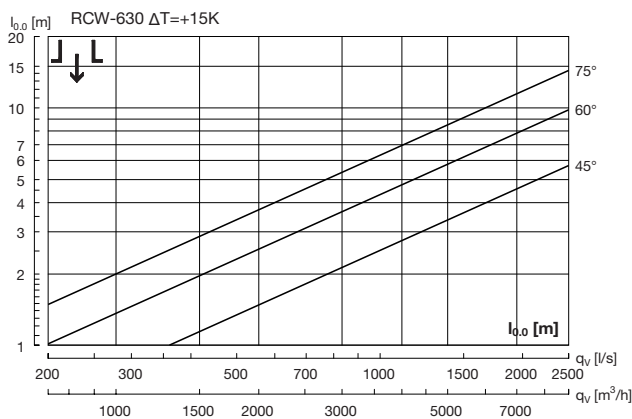
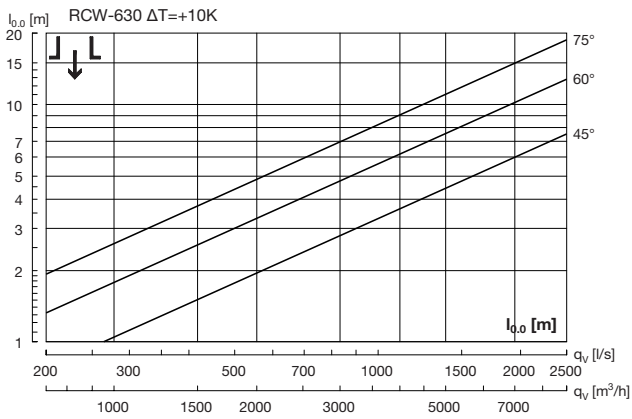
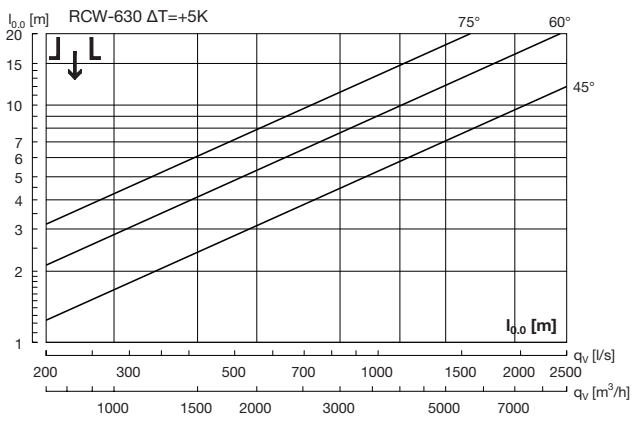
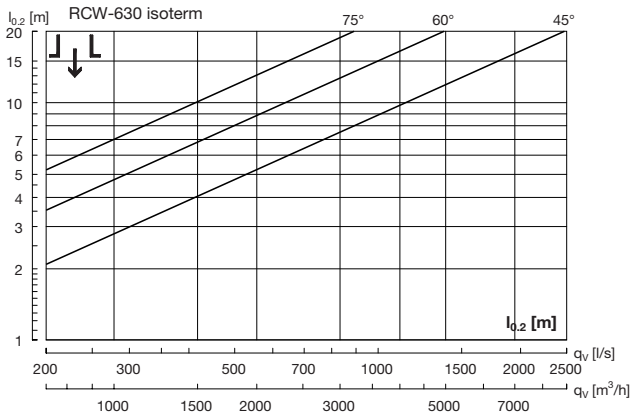



Most of us spend the majority of our time indoors. Indoor climate is crucial to how we feel, how productive we are and if we stay healthy.

We at Lindab have therefore made it our most important objective to contribute to an indoor climate that improves people's lives. We do this by developing energy-efficient ventilation solutions and durable building products. We also aim to contribute to a better climate for our planet by working in a way that is sustainable for both people and the environment.

[Lindab](#) | For a better climate