

Monitoring system EKO-KE16



Description

The EKO-KE16 control and monitoring system is intended for use in the automatic monitoring and performance testing of up to 16 (two dampers/group) fire/smoke dampers, smoke dampers or pressure relief dampers with 24 V damper motors and various types of smoke detector.

EKO-KE16 uses a built-in transformer to provide power to both actuators and smoke detectors. The unit has been developed using the latest technology and meets the requirements for a monitoring system laid down in the Swedish National Board of Housing, Building and Planning's General Guidelines, as well as the applicable standards of VVS AMA 09.

Function – Indication

EKO-KE16 is equipped with 19 LEDs that indicate the operating status of the control unit and each of the damper groups, plus a test button for damper performance testing and a reset button to reset alarms. When the system is starting up, EKO-KE16 detects which damper inputs are connected. The LEDs for "Normal" and "Alarm/Error" flash during startup. This takes around five minutes.

Reset

Alarms or errors are reset manually using the reset button on the front of the monitoring unit. The monitoring system is reset automatically once the external alarm has been reset. (Optional, see page 3)

Automatic performance testing/time

The EKO-KE16 control and monitoring system performance tests connected dampers 10 hours after the unit has been supplied with voltage or after the manual test has been conducted; the unit is then performance tested every 48 hours. This displacement is to avoid performance testing taking place during the daytime. The option to conduct performance testing at other time intervals or at other times can be enabled by connecting an external timer to "Trigg in" and setting DIP switch 4 to the ON position. Once the performance test is complete, which takes around four minutes, the green operating LED and green LED at every damper indicate normal position. If the test has failed, it will be repeated once more in order to minimise failure alarms. If this test also fails, a failure alarm will be generated.

Manual performance test

The dampers can be performance tested by pressing the test button for automatic function test located on the front of the monitoring unit. The internal clock is reset for every performance test, which means that this function can also be used to change the time the performance test takes place.

Electrical installation

The unit is intended for permanent installation and must be preceded by an all-pole power switch with a gap of at least 3 mm.

Function and location of LEDs

Colour	Location	Light	Function
Green	1	Non-flashing	Operation/power on
Red	2	Non-flashing	Fire alarm
Yellow	3	Non-flashing	Detector loop error
Yellow	3	Flashing	Damper error
Red/Yellow	2 & 3	Flashing	Service alarm detector
Green	4	Non-flashing	Normal mode
Red	5	Non-flashing	Alarm mode
Red/Yellow/Green	1, 2, & 3	Non-flashing	Night closing dampers

When the system is starting up, EKO-KE16 detects which damper inputs are connected.

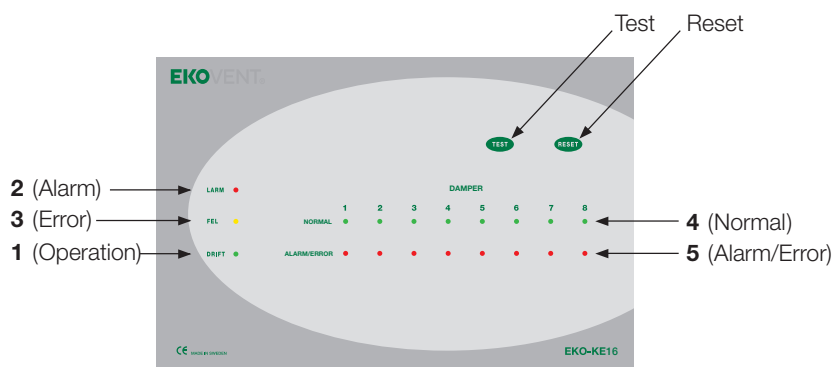

Technical data for Monitoring system EKO-KE16

Measurement data

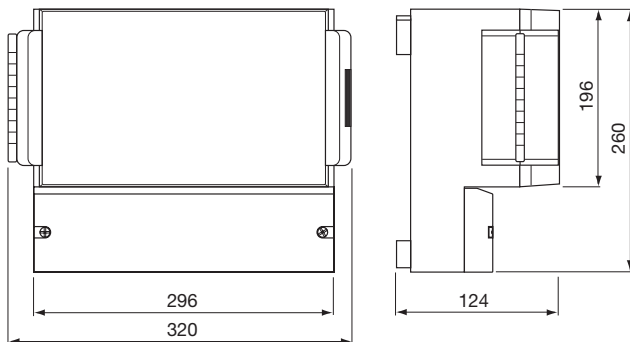

Technical data

Supply voltage	AC 220–230 V, 50/60 Hz
Power consumption	160 VA
Alarm outputs	Potential-free break contacts, 230 V, 5 A
Alarm input	10 mA closed position, 1.8 V open position*
EMC	SS-EN50 130-4
Max number of smoke detectors	30
Ambient temperature	0°C to +43°C
Enclosure class	IP 65
Weight	3.8 kg

* Connected contact must be potential-free.

Terminal block description for Monitoring system EKO-KE16

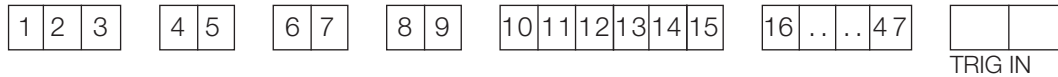

Terminal 1: L/phase 230 V Terminal 2: N/neutral 230 V Terminal 3: PE	Terminal 12: External alarm input 1 Terminal 13: External alarm input 1
Terminal 4: Buzzer alarm 1/fan output* Terminal 5: Buzzer alarm 1/fan output*	Terminal 14: External alarm input 2/Night closing Terminal 15: External alarm input 2/Night closing
Terminal 6: Buzzer alarm 2/alarm output** Terminal 7: Buzzer alarm 2/alarm output**	Terminal 16, 20, 24, 28, 32, 36, 40, 44: Actuator feed 1, AC 24 V
Terminal 8: Buzzer alarm 3/service output*** Terminal 9: Buzzer alarm 3/service output***	Terminal 17, 21, 25, 29, 33, 37, 41, 45 Actuator feed 2, +S1, +S4, AC 24 V
Terminal 10: Smoke detector loop (-) Terminal 11: Smoke detector loop (+)	Terminal 18, 22, 26, 30, 34, 38, 42, 46 Signal contact S2
	Terminal 19, 23, 27, 31, 35, 39, 43, 47: Signal contact S6
	Trigg in: External timer

- * Breaks upon power outage, function text, error and alarm
- ** Breaks upon power outage and alarm
- *** Breaks upon power outage and error

DIP switch functions (Located under the front panel)

ON = Pressed on top edge
OFF = Pressed on bottom edge

No	Function	ON	OFF	Terminal	Description
1	Smoke detector	Connected	Disconnected	10-11	Detects if detector is present even if it is not selected. In such case, flashes red and yellow even during startup.
2	Night closing	Connected	Disconnected	14-15	Alarm input 2. If night closing is not selected, no jumper is required at the input. If night closing is activated, both red and yellow light. Concluded with a manoeuvring operation.
3	Post-cooling	Connected	Disconnected	4-5	Releases buzzer alarm 1 seven minutes before manoeuvring. Manoeuvring with button has no post-cooling.
4	External trigger input	Connected	Disconnected	J10	A jumper is not necessary at the input if it is not used. If post-cooling is selected, it will be used.
5	Extra long closing and opening time	Connected	Disconnected	16-31	60 sec. closing time instead of the normal 30 sec. 400 sec closing time instead of the normal 200 sec.
6	Auto-reset of external alarm	Connected	Disconnected	12-13	Option to automatically or manually reset external fire alarm.
7	External fire alarm	Connected	Disconnected	12-13	Option to connect existing fire alarm.
8	Function test	Connected	Disconnected	4-5	When activated (on) alarm 1 does not break during function test

Connection example for Monitoring system EKO-KE16

16 dampers

Series connection, example Damper group 1

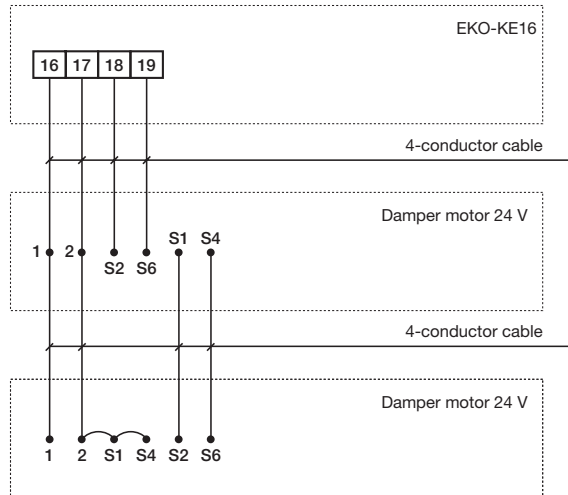

Series connection, example Damper group 2

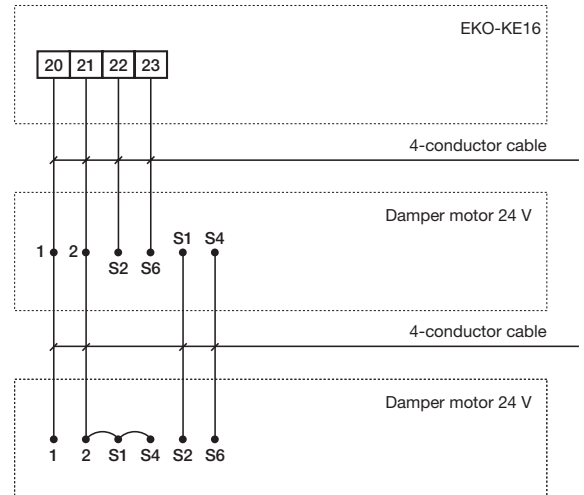

Connection of damper NOT in group

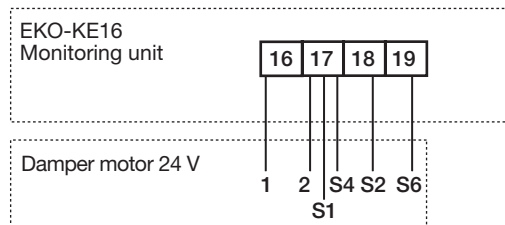

Additional connected dampers (not connected in groups) are connected in the same way in terminal 20-47.

Connection example for Monitoring system EKO-KE16

1 Duct detector EKO-RE

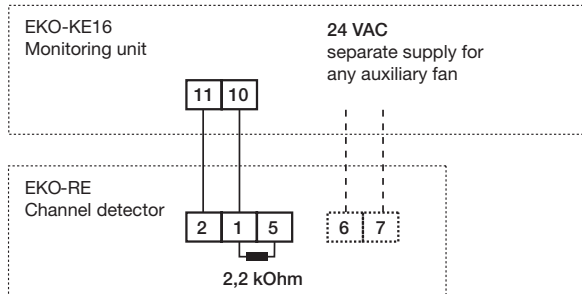

1 Room detector EKO-RET

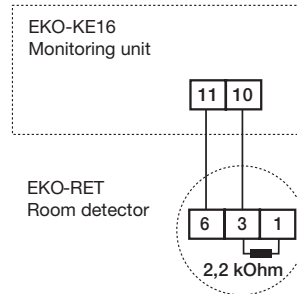

Duct detector EKO-RE in series

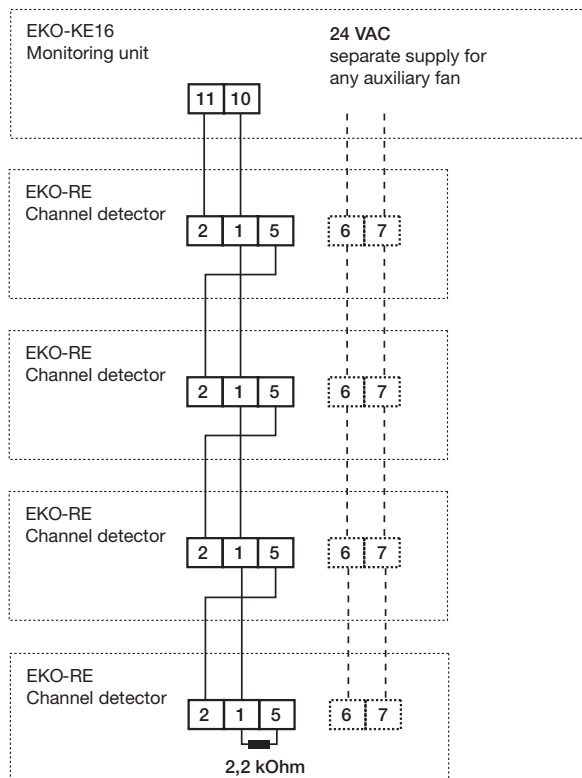

Room detector EKO-RET in series

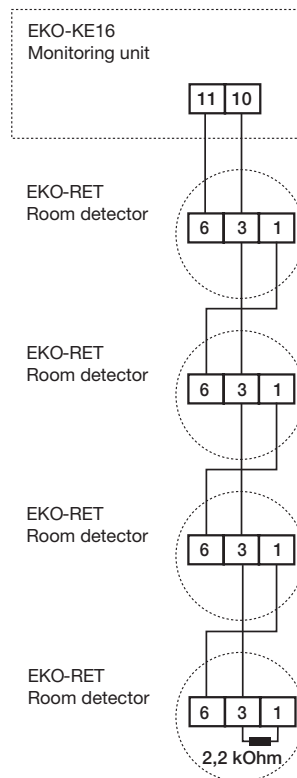

Smoke detectors connected in series

When several smoke detectors are connected in series, a terminating resistor must only be fitted to the last detector in the loop.