

Lindab **Fire System Pro**

Wiring installation instructions



FireSystemPro

Content

Fire System Pro	3
Setup overview example	3
Pro-M master unit	4
Local setup overview for Pro-M	4
Access circuit card	5
Circuit card overview	6
Circuit card connections	7
Pro-S damper unit	10
Technical setup overview for Pro-S	10
Mount and secure cables	11
Circuit card overview	12
Circuit card connections	13
Connect fire damper to damper unit.....	14
Connect smoke detector to damper unit	14
Wiring alternatives	14
Connect damper unit to power.....	15
Connect damper unit to master unit	15
Double terminals.....	15
Connect damper unit to a damer unit	15
Pro-PDT pressure transmitter	16
Installation and wiring.....	16
Pro-R signal repeater	17
Connection and wiring.....	17
Pro-SDD smoke duct detector	18
Installation and wiring.....	18
Pro-SCD smoke ceiling detector	19
Installation and wiring.....	19
Pro-DTS	20
Installation and wiring.....	20
Pro-DT	21
Wiring	21

Caution!

Read and understand the instruction before using the Lindab Fire System Pro and ensure that the installation complies with local safety regulations. Installation and maintenance of the system should only be carried out by qualified personnel. The manufacturer is not responsible for any eventual damage or injury caused by inadequate skills during installation, or through removal or deactivation of any security devices.

FireSystemPro

Fire System Pro

Lindab Fire System Pro is a complete fire protection steering system that allows to feed, monitor and test up to 60 fire and/or smoke control dampers. Smoke detectors, temperature sensors, thermostat and fault panel can also be connected to the system.

Setup overview example

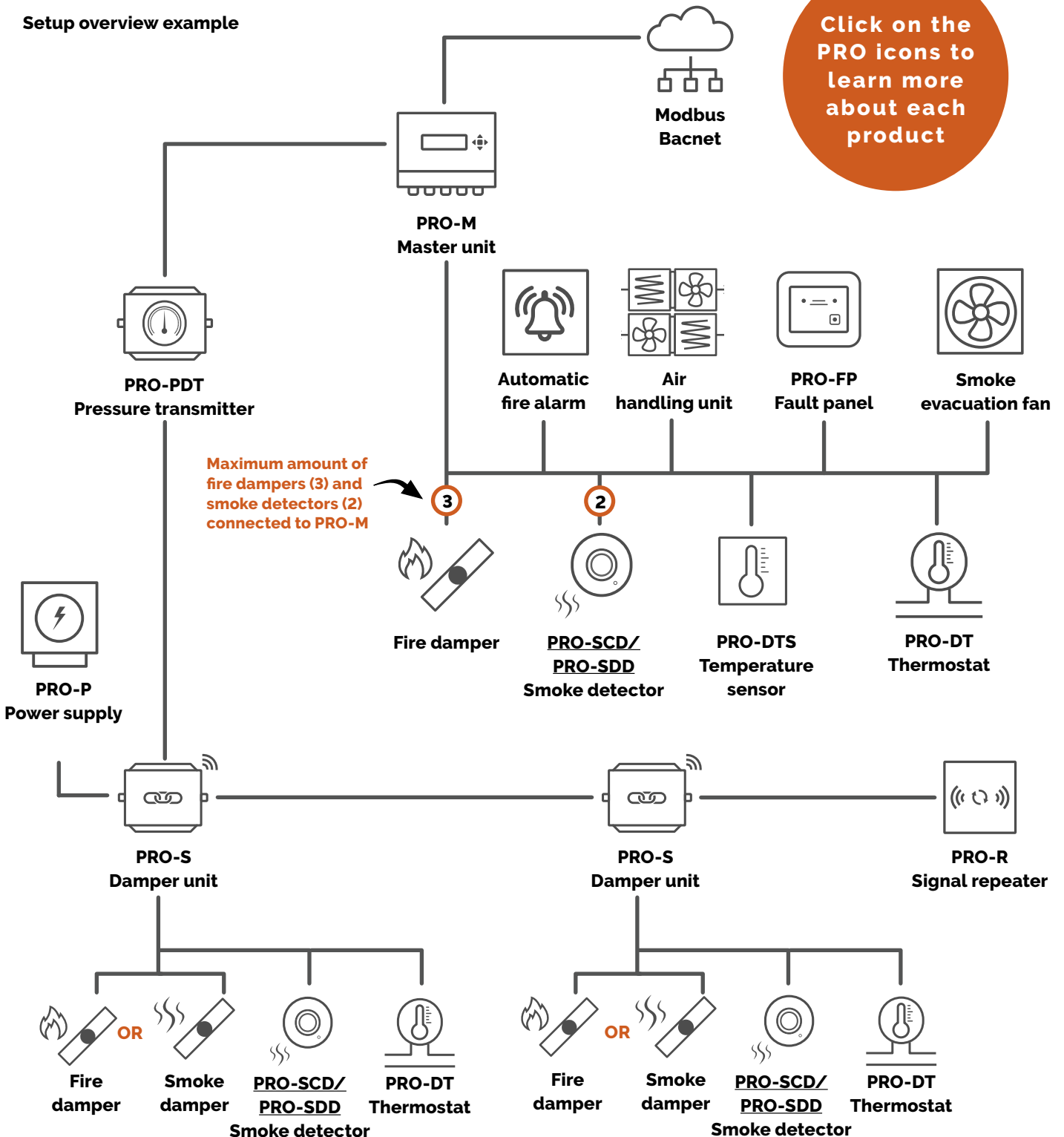

FireSystemPro

Master unit

Pro-M master unit

Pro-M is the main unit of the Fire System Pro. It can connect directly to up to four fire dampers, two smoke detectors, thermostat and/or temperature sensor. With the help of Pro-S damper unit, the Pro-M can communicate with up to a total of 60 fire dampers and/or smoke control dampers, 60 smoke detectors and 60 temperature sensors. Setup and [commissioning](#) for the system is made in Pro-M.

Local setup overview for Pro-M

Click on the PRO icons to go directly to the datasheet for each product

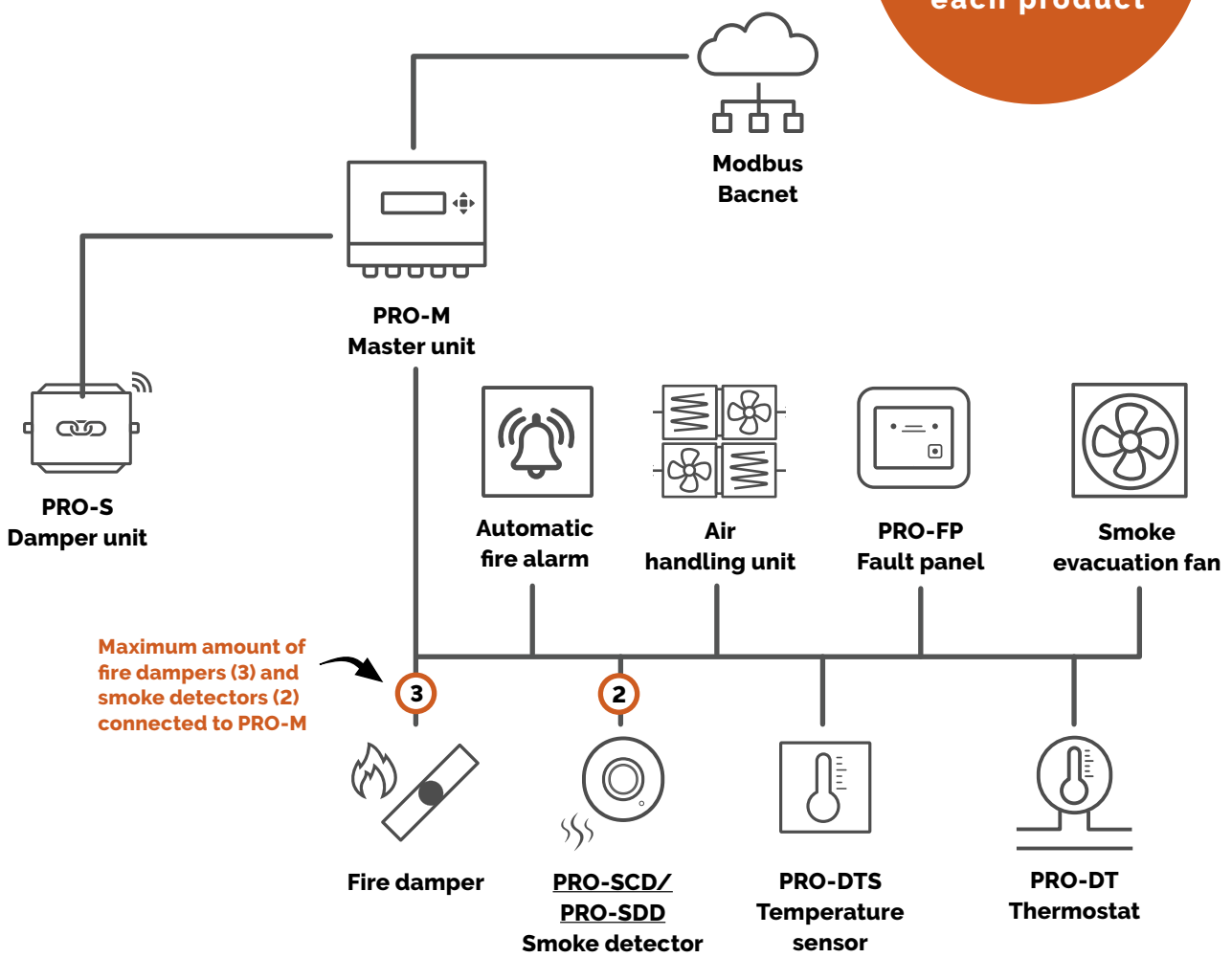

FireSystem Pro

Master unit

Access circuit card

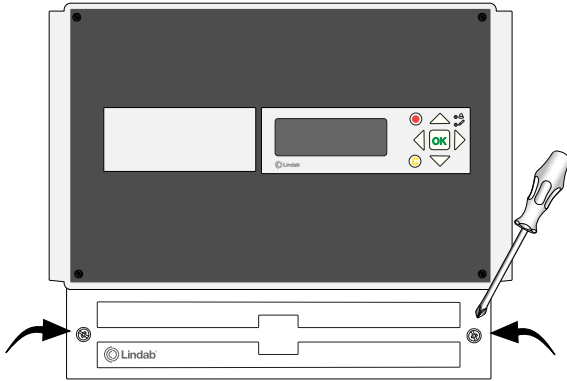

1. Unscrew the cover lid to access the circuit card.

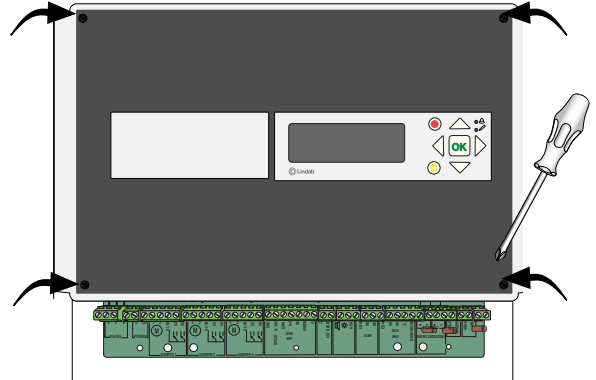

2. Unscrew and remove the front plate to access power supply, network cable and the rest of the circuit card.

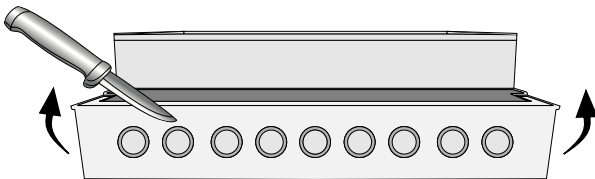

3. Carve the holes on the bottom of the unit, to open up for wiring cables.

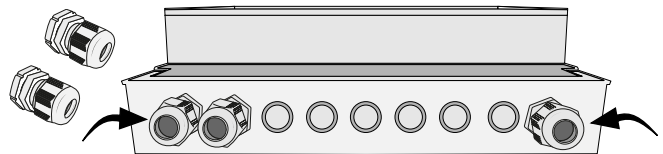

4. Install displacement joints before connecting cables.

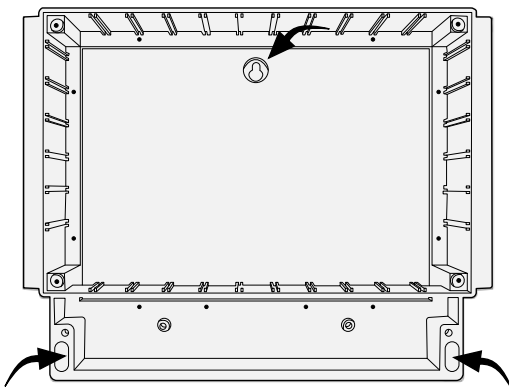

5. Mount the unit on the wall

Click here to
go directly to
the datasheet
for PRO-M

FireSystem Pro

Master unit

Circuit card overview

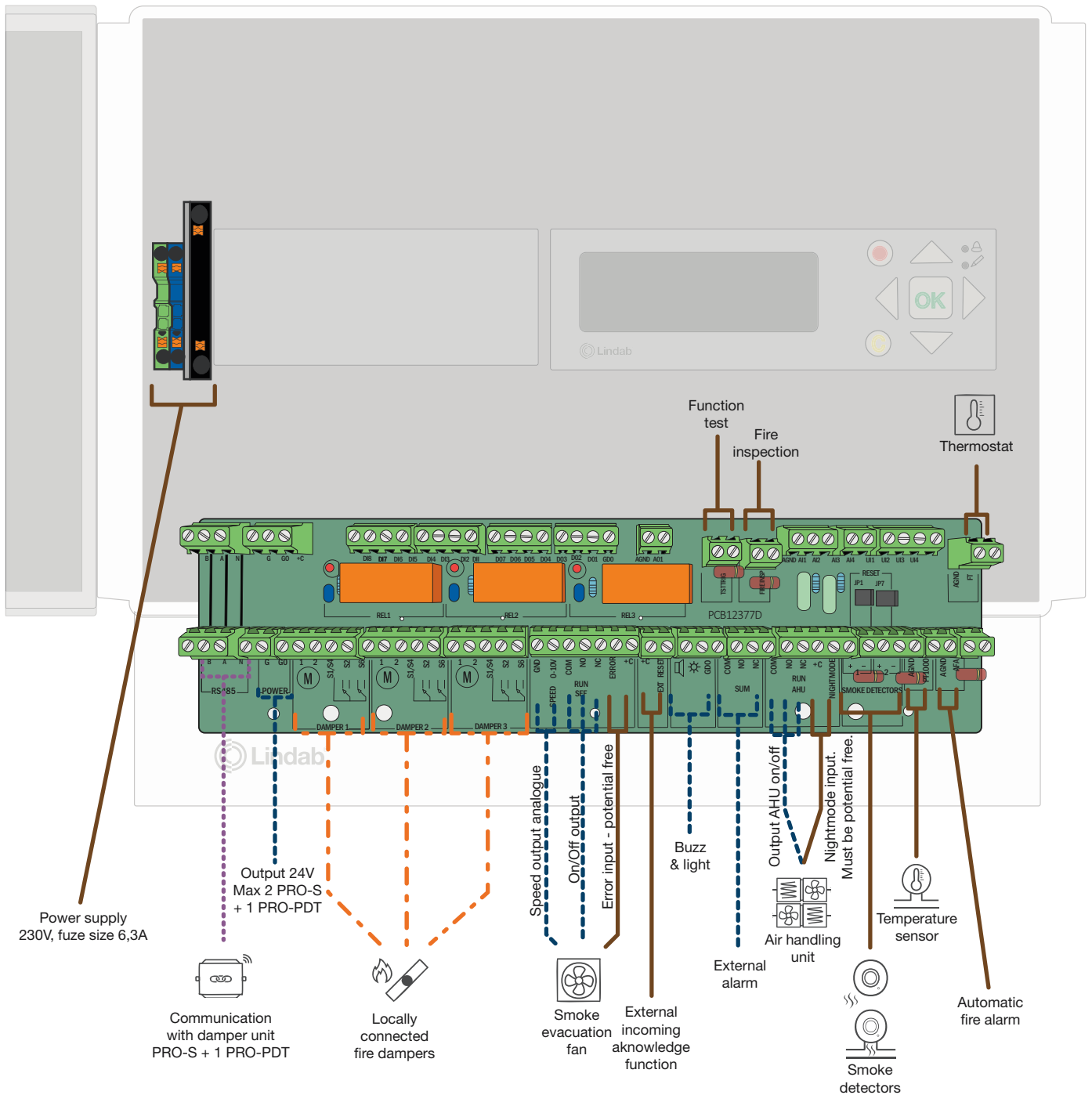
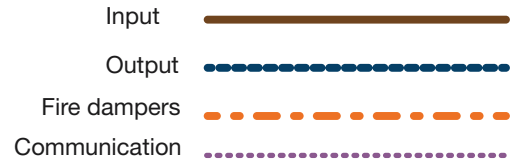

FireSystem Pro

Master unit

Circuit card connections

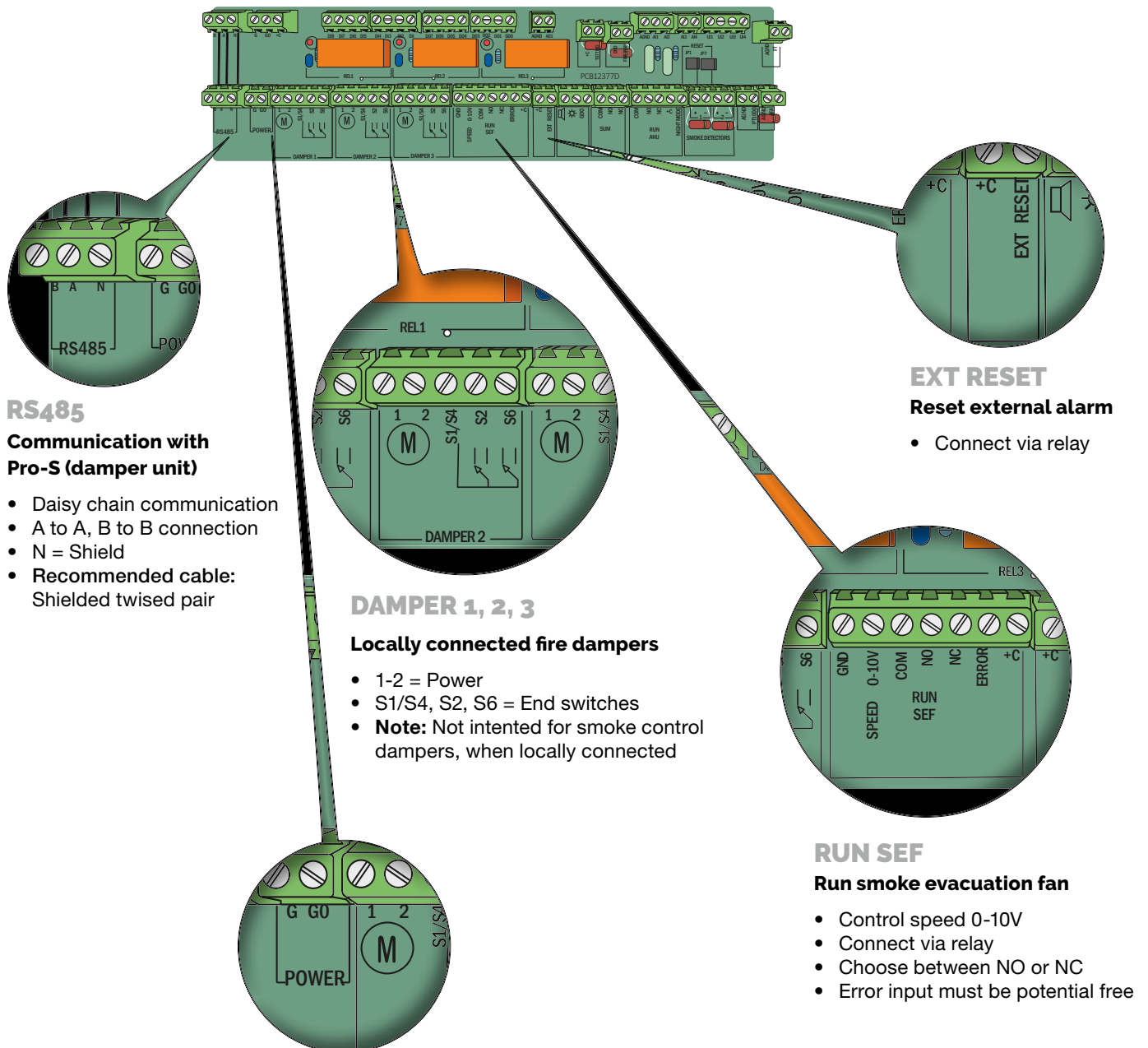

RS485 Communication with Pro-S (damper unit)

- Daisy chain communication
- A to A, B to B connection
- N = Shield
- Recommended cable: Shielded twisted pair

DAMPER 1, 2, 3 Locally connected fire dampers

- 1-2 = Power
- S1/S4, S2, S6 = End switches
- **Note:** Not intended for smoke control dampers, when locally connected

EXT RESET Reset external alarm

- Connect via relay

RUN SEF Run smoke evacuation fan

- Control speed 0-10V
- Connect via relay
- Choose between NO or NC
- Error input must be potential free

POWER 24V power supply for integrated products

- Can also supply power for two damper units (PRO-S) + one PRO-PDT
- Recommended cable: Standard 24V 1x2

FireSystem Pro

Master unit

Circuit card connections

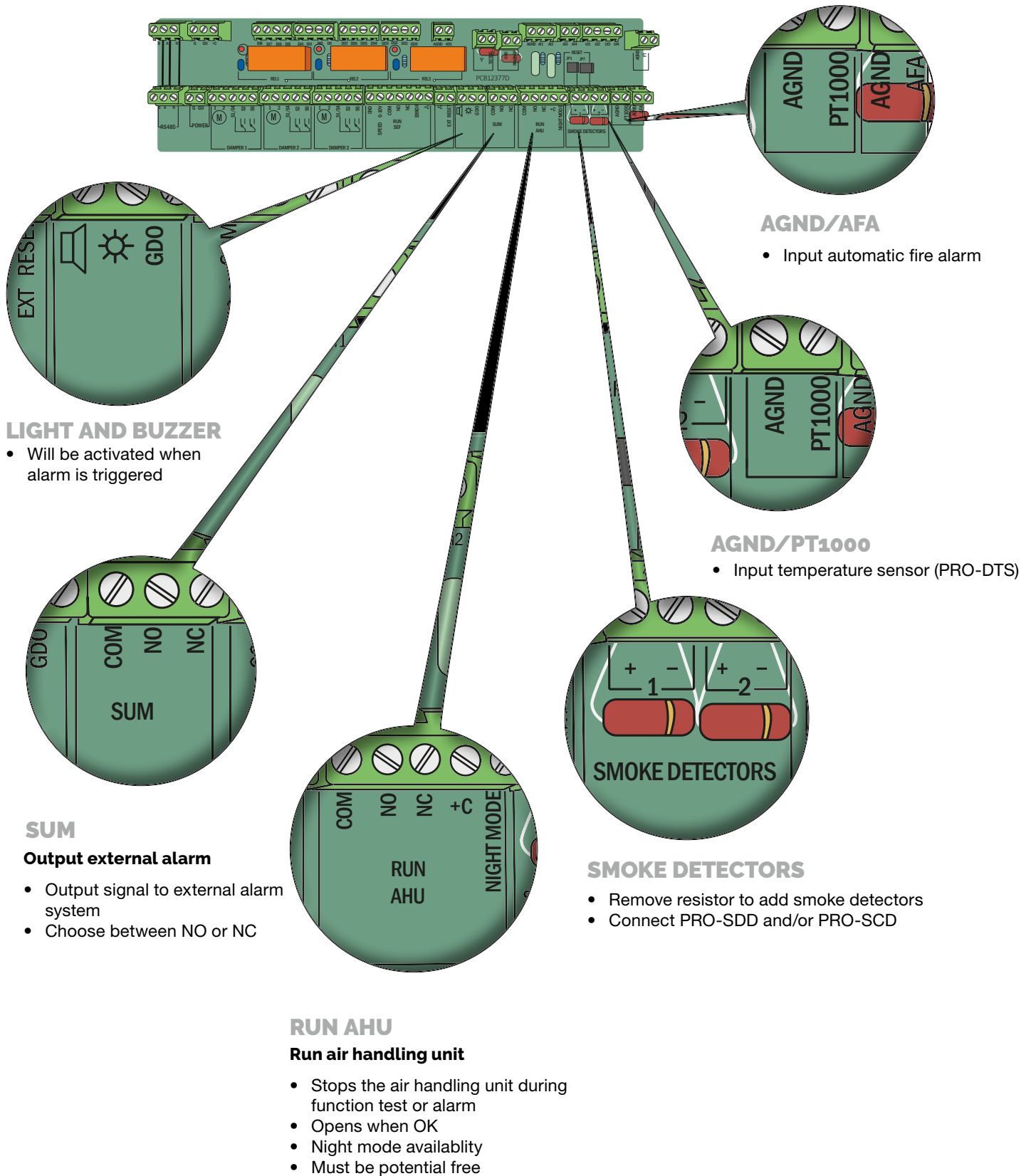

FireSystem Pro

Master unit

Circuid card connections

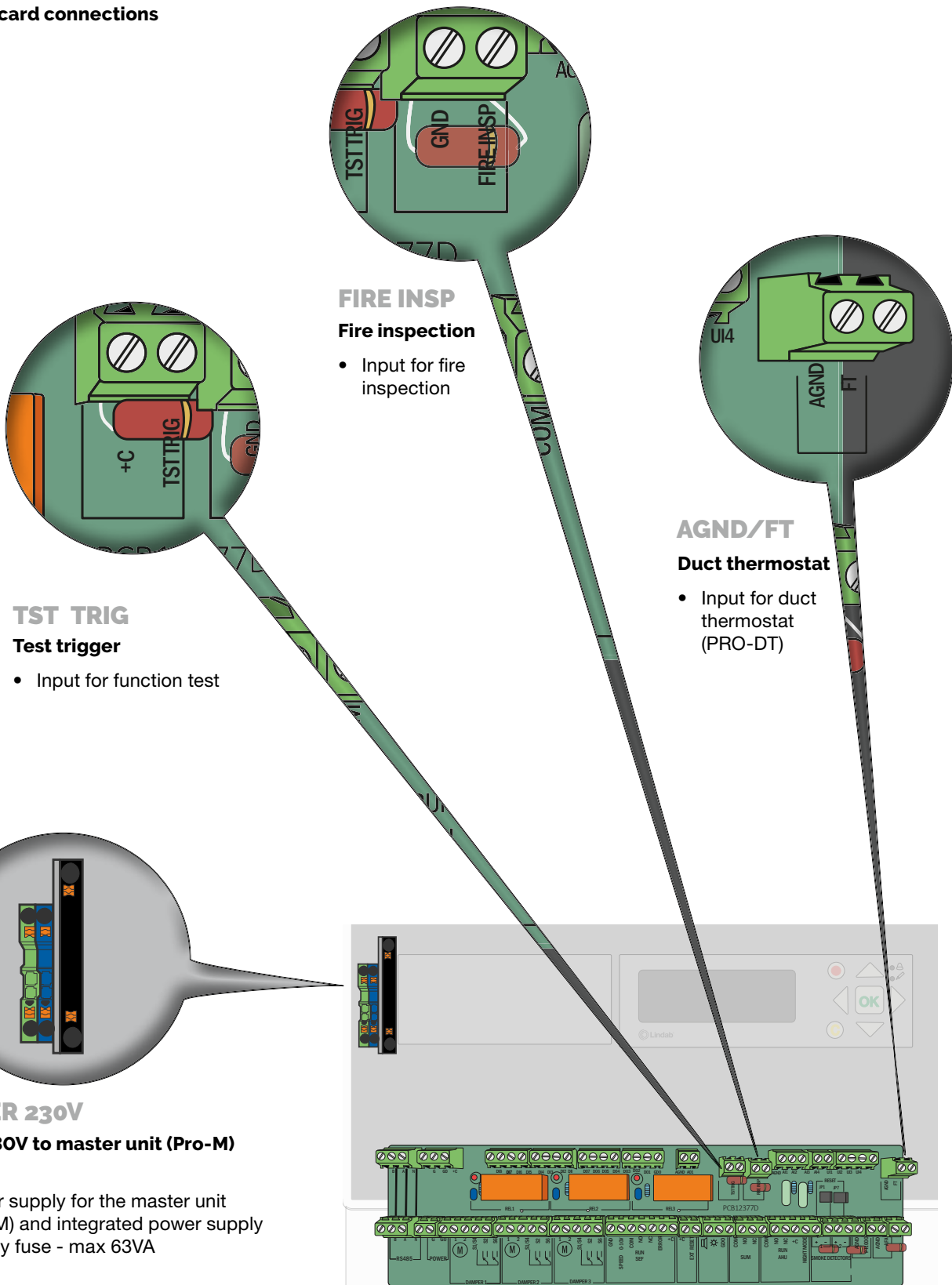

POWER 230V

Input 230V to master unit (Pro-M)

- Power supply for the master unit (Pro-M) and integrated power supply
- Supply fuse - max 63VA

FireSystemPro

Damper unit

Pro-S damper unit

Pro-S is a damper unit for the Fire System Pro and should be used when more than four fire dampers are connected to the system. It works together with the Pro-M master unit, where most of the setup of the Pro-S is made.

The Pro-S damper unit has two analogue inputs, two digital inputs, one analogue output and two digital outputs. The in- and outputs are used for e.g damper control, smoke detector, temperature sensors and VAV. It communicates via Modbus. One terminal is used as +19 V DC supply voltage for a smoke detector.

The Lindab ProLink™ app (Android and iOS) can be used to identify the units and for setting a Modbus addresses. The app can also be used to upgrade the firmware.

Technical setup overview for Pro-S

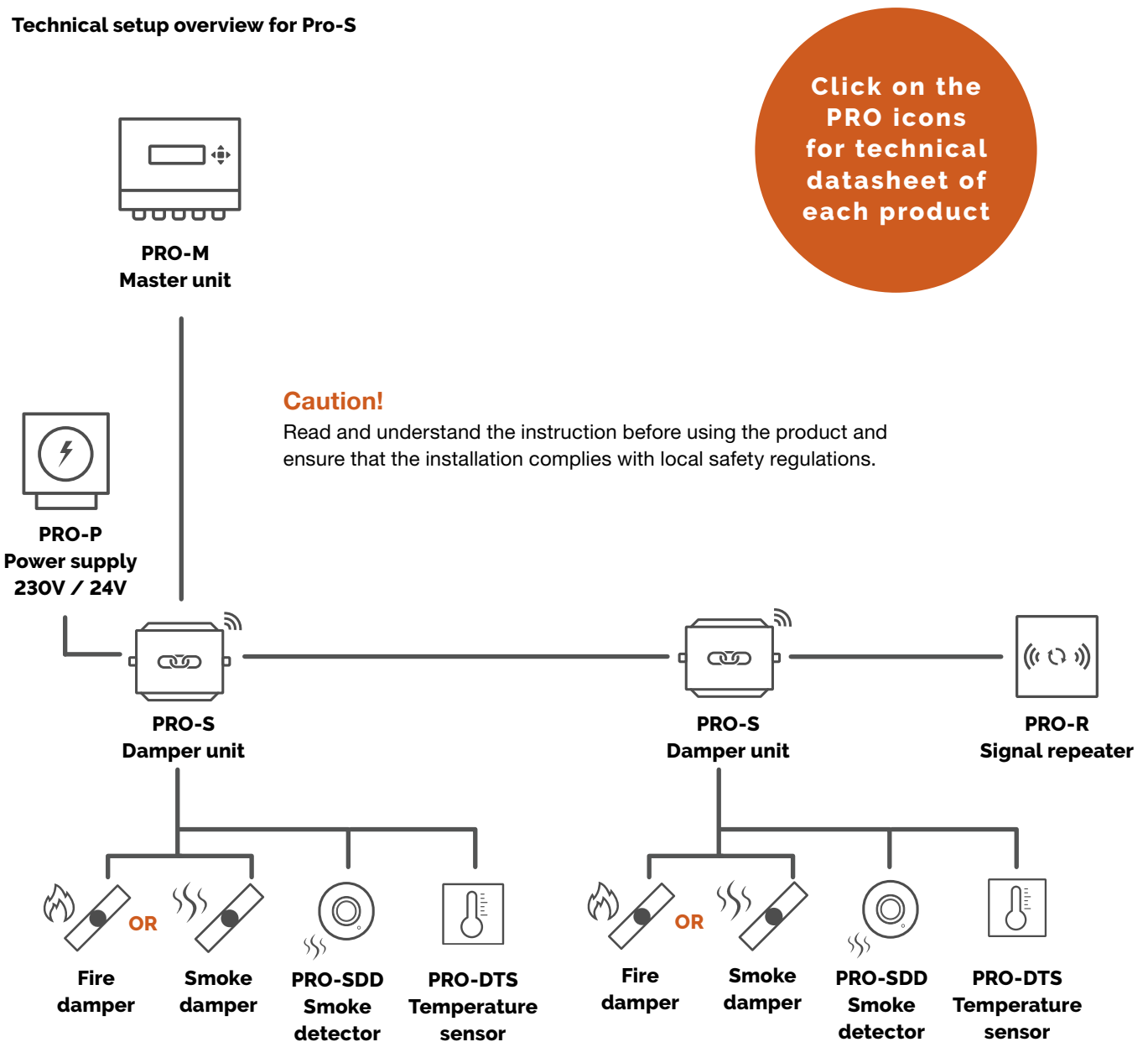

FireSystem Pro

Damper unit

Mount and secure cables

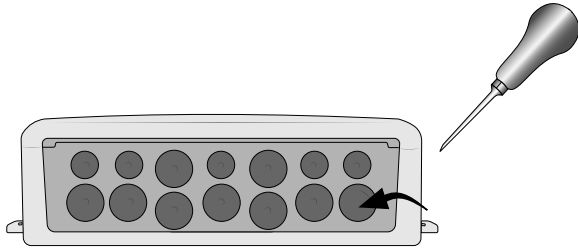

1. Pierce a hole that is smaller than the cable diameter, in the soft part of the cable front with a circular object, such as a Philips head screwdriver or an awl.

Caution!

Make sure that the hole is as small as possible (smaller than the cable diameter). The soft material in the cable front is intended to work as a seal against the cable, and if the hole is too big the unit will not be protected against humidity and dirt.

Caution!

If a hole is made in a cable gland and the cable is removed, the unit will not maintain its IP-class.

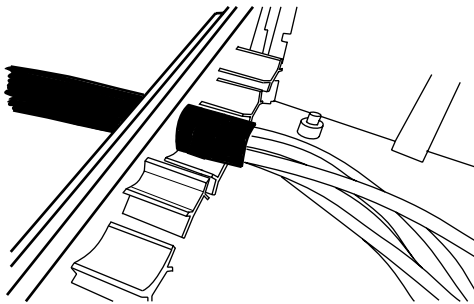

2. Push the cable through

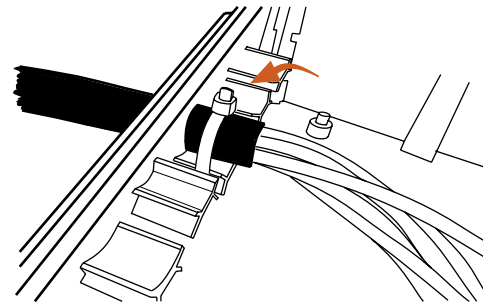

3. Secure the cables in the housing with a cable tie around the cable support. The width of the cable tie should be up to 2,8 mm.

Mounting

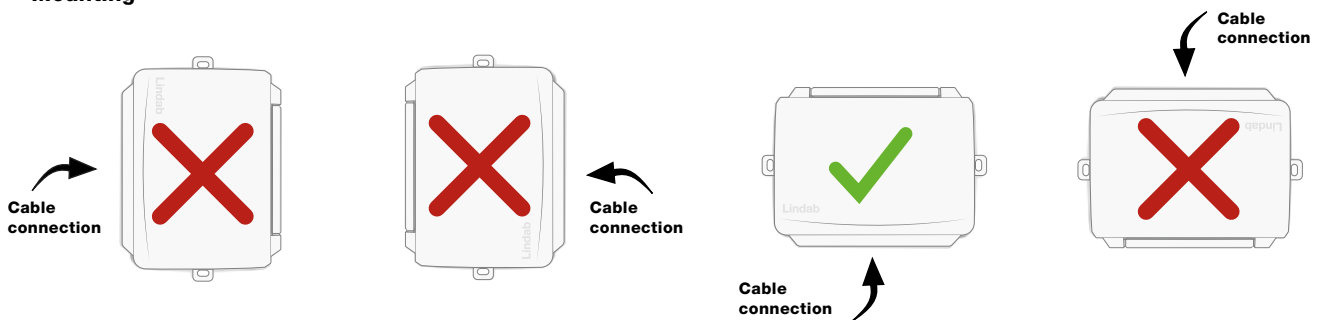

4. Mount the damper unit on a stable, vibration-free surface. The unit can be mounted horizontally (on a table, for example) with the lid facing up or vertically with the cable front of the unit pointing down (see image above).

Attention! If the unit is installed in a humid environment, install it vertically with the cable front of the unit pointing down, to allow moisture to escape.

FireSystem Pro

Damper unit

Caution!

Before installation or maintenance, the power supply should first be disconnected. Installation or maintenance of this unit should only be carried out by qualified personnel. The manufacturer is not responsible for any eventual damage or injury caused by inadequate skills during installation, or through removal of, or deactivation of any security devices.

Circuit card overview

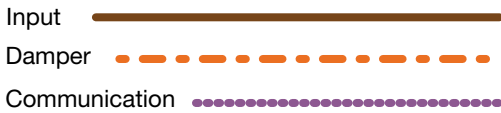

Click here to go directly to the technical datasheet for PRO-S

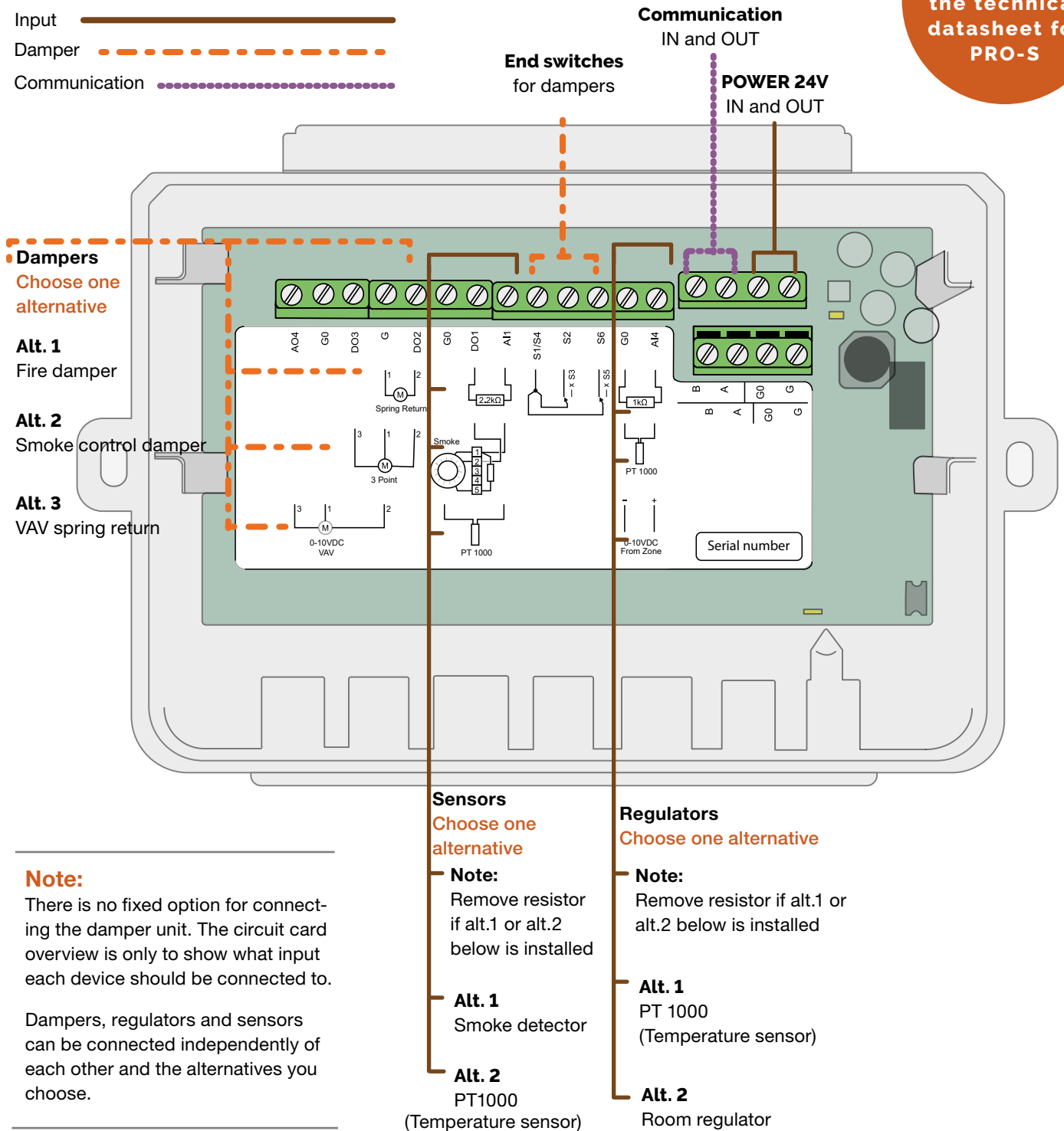

Note:

There is no fixed option for connecting the damper unit. The circuit card overview is only to show what input each device should be connected to.

Dampers, regulators and sensors can be connected independently of each other and the alternatives you choose.

FireSystem Pro

Damper unit

Circuit card connections

Note: At delivery, the unit is equipped with a 2.2 kΩ resistor mounted between terminals DO1 and AI1 and a 1 kΩ resistor between G0 and AI4. The configuration of the in- and outputs are made from the Pro-M master unit.

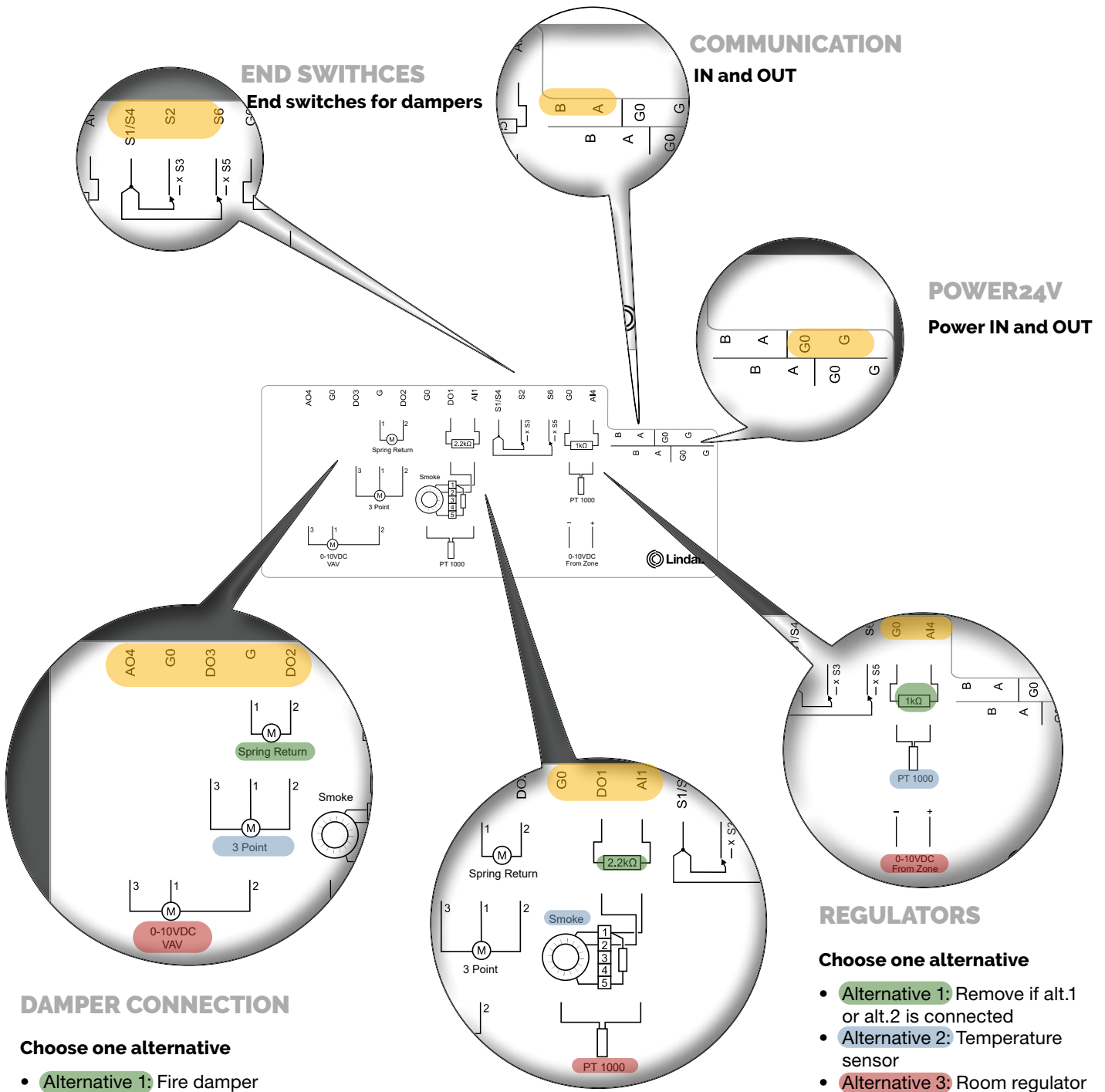

DAMPER CONNECTION

Choose one alternative

- Alternative 1: Fire damper
- Alternative 2: Smoke control damper
- Alternative 3: VAV damper

SENSOR CONNECTION

Choose one alternative

- Alternative 1: Remove if alt.1 or alt.2 is connected
- Alternative 2: Smoke detector
- Alternative 3: Temperature sensor

FireSystem Pro

Damper unit

Connect fire damper to damper unit

One fire damper per Pro-S is allowed. The damper is controlled by either an actuator with spring return, a 3-point actuator or a 0-10 V VAV actuator. When an actuator is used, end position switches must be added to terminals S1/S4, S2 and S6.

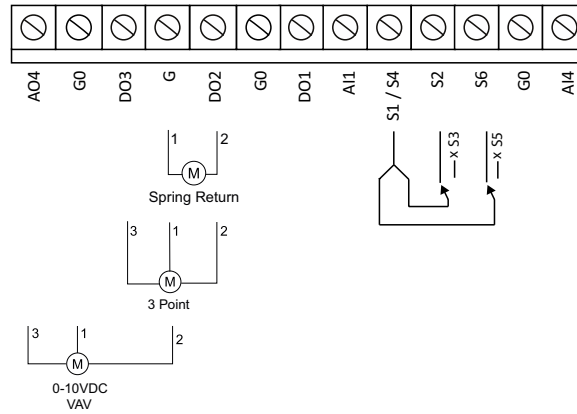

Wiring diagram 1: Actuators and end position switches

Connect smoke detector to damper unit

One smoke detector per PRO-S is allowed. Remove the 2.2 kΩ resistor from the damper unit and move it to the smoke detector. The digital output DO1 works as a +19 V DC power supply for the smoke detector. AI1 is used to read the detector status in the range 0-100mA, and is short circuit proof.

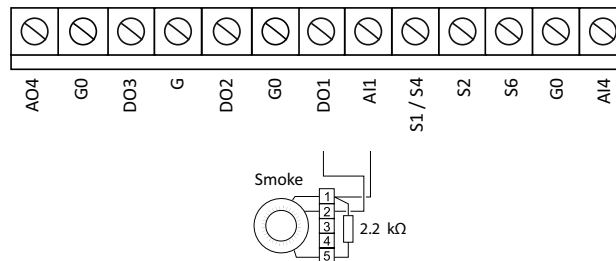

Wiring diagram 2: Smoke detector connected to power and Analogue input 1

Wiring alternatives

Temperature sensors and resistors can be added to the damper unit according to the wiring diagram 3. The 1 kΩ resistor is removed when a temperature sensor or the VAV signal 0-10 from zone is connected.

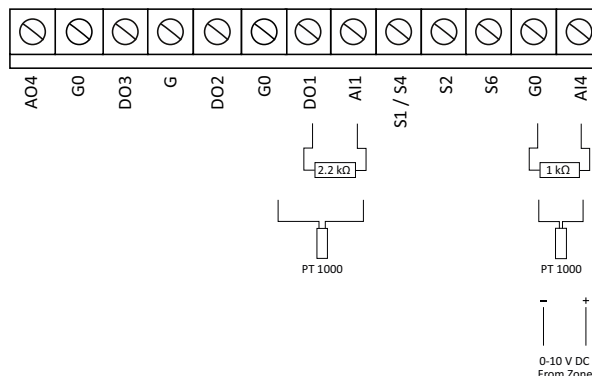

Wiring diagram 3: Wiring alternatives

FireSystem Pro

Damper unit

Connect damper unit to power

The damper unit is connected to 24 V AC power supply in terminals G and G0, see wiring diagram 4.

Connect damper unit to master unit

The damper unit is connected to the master with a RS485 communication cable, see wiring diagram 4. The cable must be a shielded, double twisted, two wired RS485 cable.

The cable is connected to the A and B terminal in the master and the damper unit, see wiring diagram 4 and 5.

Double terminals

The double terminals in the unit (wiring diagram 4) are used when two or more units are connected to each other as shown in wiring diagram 5. Both the communication cable and the cables for power supply can be connected in the upper and/or lower terminals for easy installation.

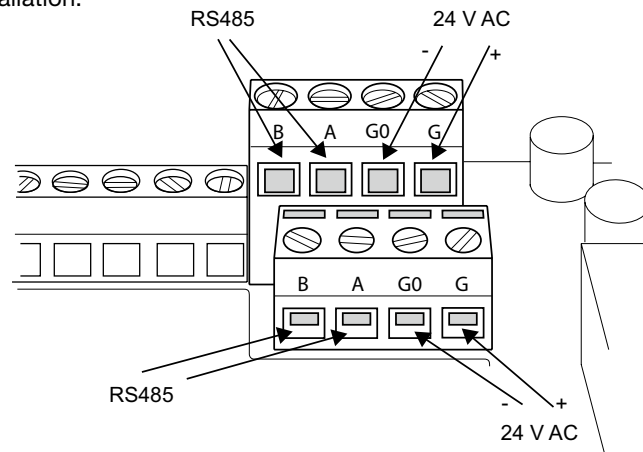

Wiring diagram 4: Connection to power and communication

Connect damper unit to a damper unit

When a damper unit is connected to another damper unit, G is connected to G, G0 to G0 (Power supply), A to A and B to B (communication, RS485), see wiring diagram 5.

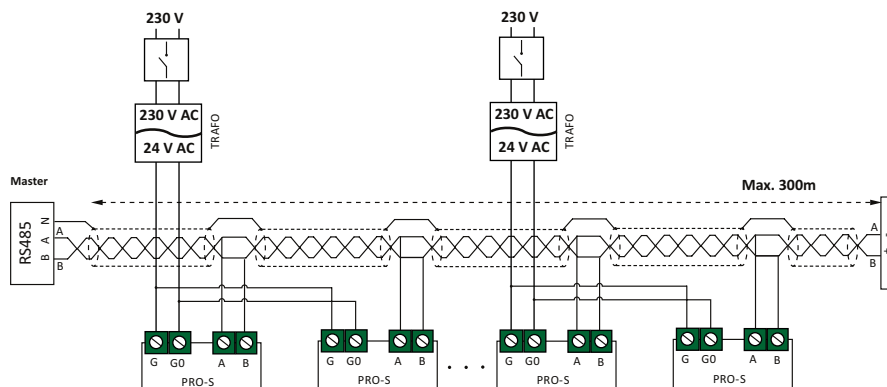

Wiring diagram 5: Damper units connected to a master unit and external power supplies.

Attention!

The 2-wire shielded twisted pair RS485 cable needs to be connected to G0 in Pro-S every first slave after the transformer as displayed in the figures above.

FireSystem Pro

Pressure transmitter

Pro-PDT pressure transmitter

PRO-PDT is a pressure transmitter used for the Fire System Pro. It is equipped with one pressure sensor, two universal inputs, two universal outputs and an RS485 port for Modbus communication. PRO-PDT is especially well suited as distributed I/O module for air handling unit controllers.

The transmitter operates as a Modbus slave, relieving the controller of an analogue pressure input, two universal inputs and two universal outputs. This means that less wiring is required, reducing both material costs as well as the amount of work needed.

Due to the use of MEMS dual-chip medical grade sensor the transmitter offers very high accuracy and excellent long-term stability.

Installation and wiring

The unit can be mounted either vertically or horizontally. If it is installed in a humid environment, vertical mounting is recommended to allow moisture to escape.

Installing the product is made easily since the unit has three separate cable inlets, a large angled terminal and generous space. The communication configuration is both flexible and easy as it can either be done via a menu system, which is easy to navigate, or via Modbus.

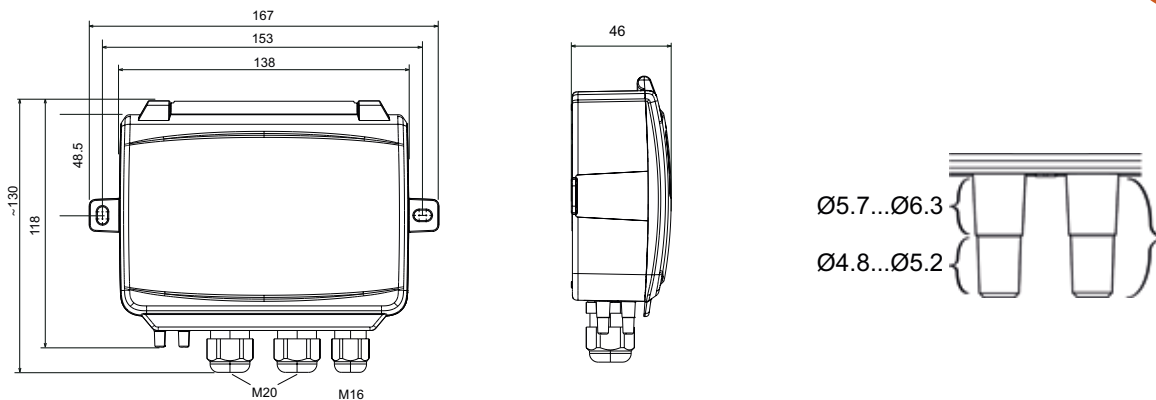

Dimension drawing of Pro-PDT, measures in mm

Mounting

Mount the pressure transmitter on a stable, vibration-free surface. The unit can be mounted horizontally (on a table, for example) with the lid facing up or vertically with the cable front of the unit pointing down (see image below).

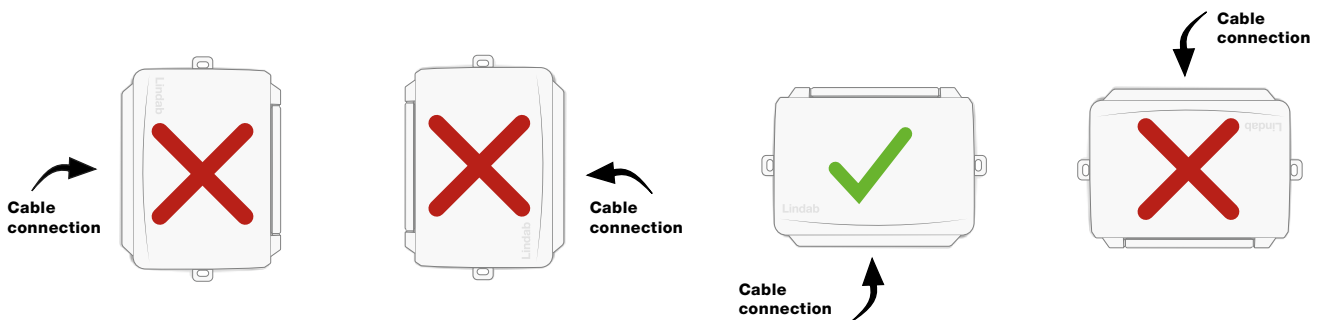

Attention! If the unit is installed in a humid environment, install it vertically with the cable front of the unit pointing down, to allow moisture to escape.

Fire System Pro

Repeater

Pro-R signal repeater

Pro-R is a signal repeater used in the Fire System Pro, provided with its own 230V stabilized power supply. It is used to enhance the RS-485 signal quality and is required if more than 30 damper units (Pro-S) are connected to the system or if the communication cable is longer than 300 meter. Both RS485 cables and the 24V DC power supply are connected to Pro-R via removable 10-pin terminal blocks.

Connection and wiring

Connect Pro-R signal repeater to Pro-S damper unit

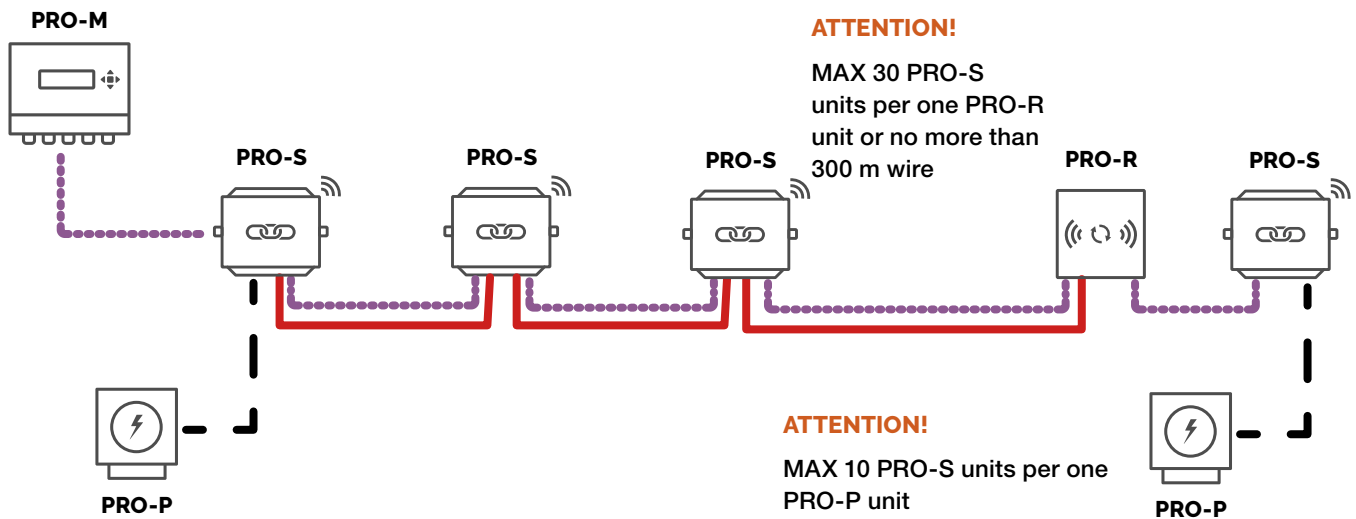
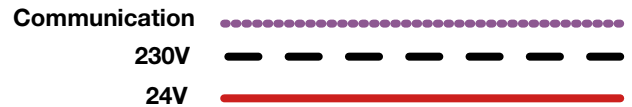

Wiring Pro-R

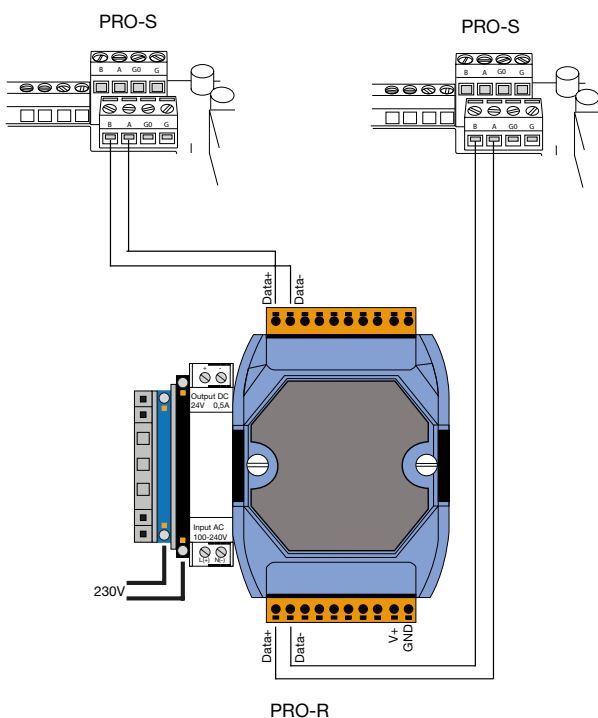

Click here to go directly to the technical datasheet for PRO-R

FireSystemPro

Smoke detector

Pro-SDD smoke duct detector

Pro-SDD is an optical smoke detector for duct mounting in all types of premises and reacts to visible smoke particles. It consists of a detector head and a base, that comes with a bayonet mount to simplify service and maintenance.

Installation and wiring

Connect Pro-SDD to Pro-M master unit

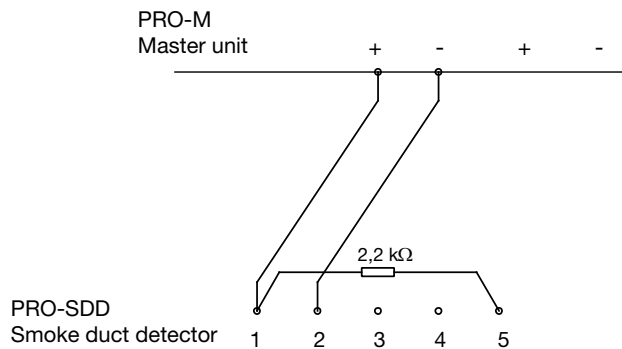

Click here to go directly to the technical datasheet for PRO-SDD

Connect Pro-SDD to Pro-S damper unit

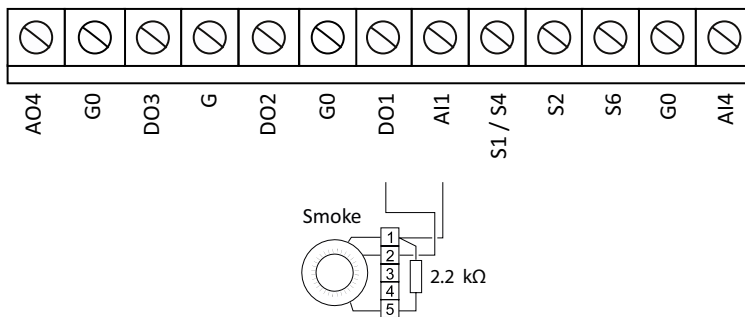

One smoke detector per Pro-S damper unit is allowed

Note:

Pro-M and Pro-S circuit cards have one 2.2 kΩ resistors on each smoke detector connection.

When connecting a smoke detector to master/damper unit, remove the resistor from the unit's circuit card and add it to the smoke detector.

The resistor is still required on the smoke detector, see illustration to the right.

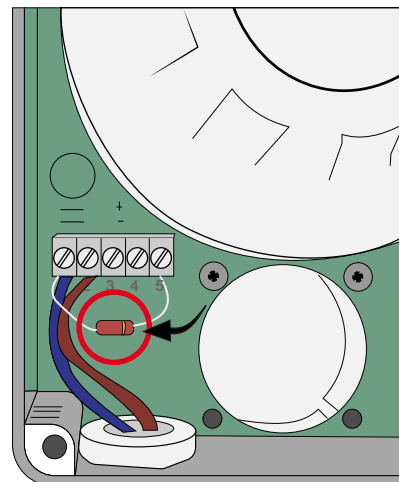

Move the resistor from Pro-M/Pro-S to Pro-SDD

FireSystem Pro

Smoke detector

Pro-SCD smoke ceiling detector

Pro-SCD is an optical smoke detector for duct mounting in all types of premises and reacts to visible smoke particles. It consists of a detector head and a base, that comes with a bayonet mount to simplify service and maintenance.

Installation and wiring

Connect Pro-SCD to Pro-M master unit

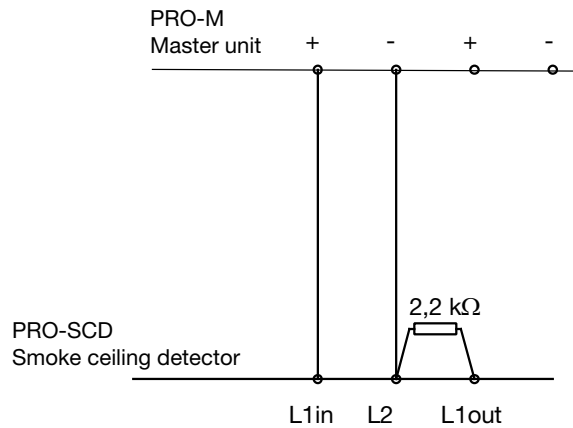

Click here to go directly to the technical datasheet for PRO-SCD

Connect Pro-SCD to Pro-S damper unit

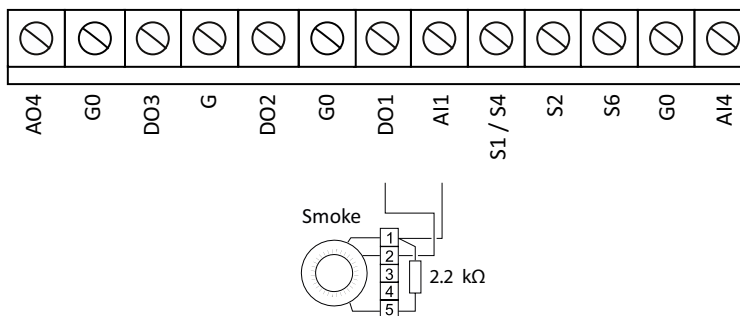

One smoke detector per Pro-S damper unit is allowed

Note:

Pro-M and Pro-S circuit cards have one 2.2 kΩ resistors on each smoke detector connection.

When connecting a smoke detector to master/damper unit, remove the resistor from the unit's circuit card and add it to the smoke detector.

The resistor is still required on the smoke detector, see illustration to the right.

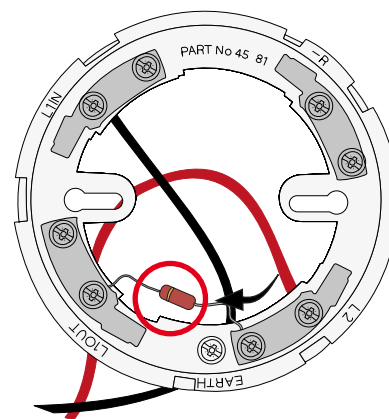

Move the resistor from Pro-M/Pro-S to Pro-SCD

FireSystemPro

Temperature sensor

Pro-DTS

Pro-DTS duct sensor measures the air temperature in ventilation and air handling installations. It can be used for a wide range of applications and is suitable for all environments. Since the mounting bracket is made of a flexible material it closes tightly against the duct.

Installation and wiring

The duct sensor is very easy to mount and has an adjustable insertion length. The terminal block for connecting the analog input to a controller is located under the cover. The cover is easily removed from the base with a twist. The sensor is designed so that the seal remains in the cover at all times and the cable gland is replaceable.

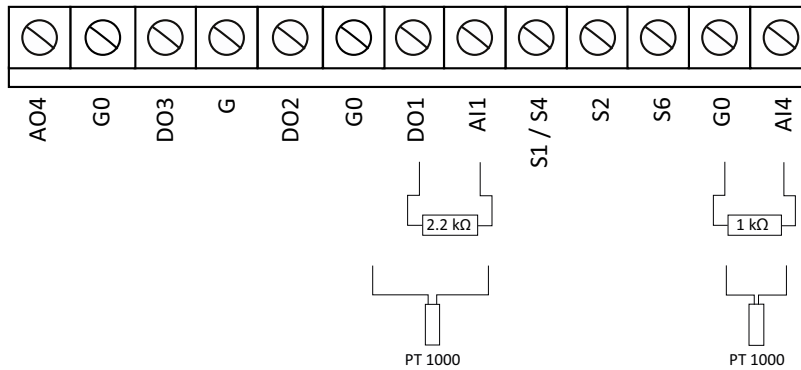

[Click here to go directly to the technical datasheet for PRO-DTS](#)

FireSystem Pro

Thermostat

Pro-DT

Pro-DT is an electro-mechanical thermostat, constructed for duct mounting and is a recommended choice for the Lindab System Pro. The capillary tube is a liquid-filled copper bulb with a 200 mm protection spring area and a mounting bracket. The micro-switch is capable of breaking up to 15 A at 230V AC.

Wiring

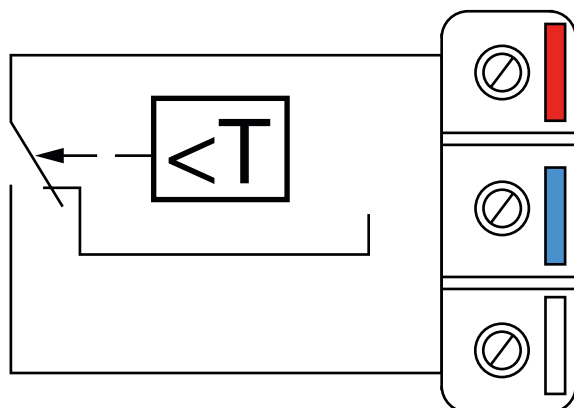

Heating

Connect to the red and blue terminal. The contact will open when the temperature rises.

Cooling

Connect to the red and white terminal. The contact will open when the temperature drops.

Logic activation

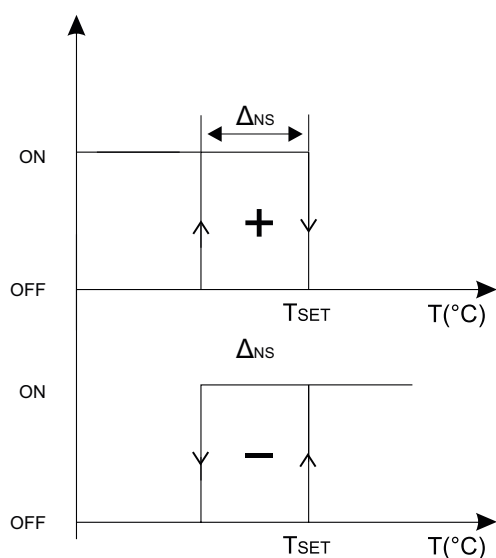

Heating Contacts: red-blue

Cooling contacts: red-white

ΔNS: Hysteresis in the stage

TSET: Setting setpoint

ON: Closed contact

OFF: Open contact

Click here to go directly to the technical datasheet for PRO-DT



Most of us spend the majority of our time indoors. Indoor climate is crucial to how we feel, how productive we are and if we stay healthy.

We at Lindab have therefore made it our most important objective to contribute to an indoor climate that improves people's lives. We do this by developing energy-efficient ventilation solutions and durable building products. We also aim to contribute to a better climate for our planet by working in a way that is sustainable for both people and the environment.

[Lindab | For a better climate](#)